

rotork®

Keeping the World Flowing
for Future Generations

Valve Positioners and Accessories



Reliability in critical flow control applications

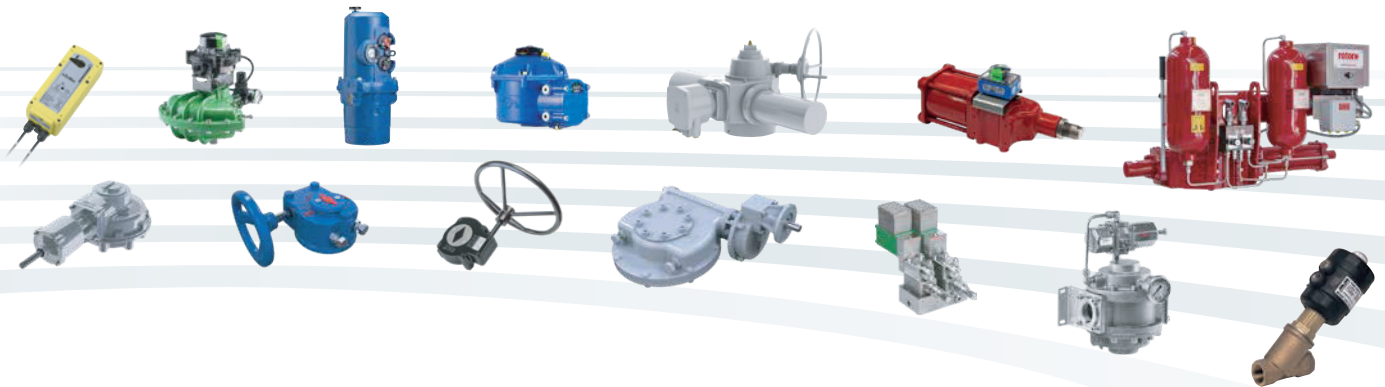

› Reliable operation when it matters

Assured reliability for critical applications and environments. Whether used infrequently or continuously, Rotork products will operate reliably and efficiently.

› Quality-driven global manufacturing

We offer products that have been designed with over 60 years of industry and application knowledge. Our research and development ensures cutting edge products are available for multiple applications across multiple industries.

› Customer focused service and worldwide support

Rotork solve customer challenges and develop new solutions that are tailored to the needs of our clients. We offer dedicated, expert service and support from initial inquiry, to product installation, to long term after sales care.

› Low cost of ownership

Long-term reliability prolongs service life. Rotork helps to reduce long term cost of ownership and provides greater efficiency to process and plant.

Valve Positioners and Accessories

Section	Page	Section	Page
Rotork	2	Lock-up Valves	25
Valve Positioner Features Summary	4	Snap Acting Relays	26
Smart Positioner	6	Solenoid Valve	27
Pneumatic-Pneumatic Positioner	7	Position Transmitters	28
Electro-Pneumatic Positioners	8	Limit Switch Boxes	30
Smart Positioners	10	Examples for Installation	32
IP Converters	22	Brackets and Levers	34
Air Filter Regulators	23	Appendix A: Equipment Certification Requirements for Hazardous Locations	36
Volume Boosters	24	Appendix B: Certifications	38



Comprehensive product range serving multiple industries

Rotork products offer improved efficiency, assured safety and environmental protection across all sectors within the Oil and Gas, Water and Power, and Chemical, Process and Industrial industries.

Market leaders and technical innovators

We have been the recognised market leader in flow control for over 60 years.

Our customers rely upon Rotork for innovative solutions to safely manage the flow of liquids, gases and powders.

Global presence, local service

We are a global company with local support.

Manufacturing sites, service centres and sales offices throughout the world provide unrivalled customer services, fast delivery and ongoing, accessible support.

Corporate social responsibility is at the heart of our business

We are socially, ethically and environmentally responsible and committed to embedding CSR across all our processes and ways of working.

Valve Positioner Features Summary



Type	Top Mounted	P/P	E/P		Smart		
Model	TMP-3000	YT-1200	YT-1000	YT-1050	YT-2500	YT-2550	
Page	8	9	10	10	20	20	
Certification	Explosion proof	-	-	✓	✓	-	-
	Intrinsically safe	-	-	✓	-	✓	✓
	ATEX/IECEX	-	-	✓	✓	✓	✓
	FM/CSA	-	-	✓	-	-	-
	KCs	-	-	✓	✓	✓	✓
	EAC	-	-	✓	✓	✓	✓
	NEPSI	-	-	✓	-	✓	-
	TIIS	-	-	✓	-	-	-
	TS	-	-	✓	-	-	-
	EMC	✓	-	✓	-	✓	-
SIL Certified	-	-	-	-	-	-	
Hardware	Technology	Solenoid	Bellows	Torque Motor	Torque Motor	Piezo	Piezo
	Local Buttons	✓	-	-	-	✓	✓
	LCD Display	✓	-	-	-	✓	✓
	Single / Double	✓	✓	✓	✓	✓	✓
	Linear / Rotary	Linear Only	✓	✓	✓	✓	✓
	Feedback	NCS	Spring Return	Spring Return	Spring Return	Potentiometer	Potentiometer
	Fail-safe	✓	✓	✓	✓	✓	✓
	Fail-freeze	✓	-	-	-	✓	✓
	Natural Gas capability	-	-	-	-	-	-
	IP Rating	IP67	IP66	IP66	IP66	IP66	IP66
NEMA rating	-	-	NEMA 4X	-	-	-	
Enclosure Material	PPS	Aluminium	Aluminium	STS316	Aluminium	STS316	
Diagnostics	Mounting Error	-	-	-	-	✓	✓
	Supply Air Check	-	-	-	-	✓	✓
	Range Error	-	-	-	-	✓	✓
	Partial Stroke Test	-	-	-	-	-	-
Feedback Option	Analogue 4 - 20 mA	-	✓ ¹	✓	-	✓	✓
	Mechanical switches	-	✓ ¹	✓ ¹	-	✓	✓
	Proximity sensors	-	✓ ¹	✓ ¹	-	✓	✓
	Transistor switches (soft. type)	-	-	-	-	-	-
Comm.	HART	-	-	-	-	Ver. 5	Ver. 5

Notes:

1. Available for rotary version only. In case of hazardous Ex installation area external mount through limit switch box is required.
2. NEPSI and EMC only for YT-3300, not for YT-3303.



Smart							
YT-2600	YT-3300/3	YT-3301	YT-3350	YT3700	YT3750	YT-3400	YT-3450
22	12	12	12	14	14	18	18
✓	-	-	-	-	-	✓	✓
-	✓	✓	✓	✓	✓	-	-
✓	✓	✓	✓	✓	✓	✓	✓
-	✓	✓	✓	✓	✓	✓	✓
✓	✓	✓	✓	✓	✓	✓	✓
✓	✓	✓	✓	✓	✓	✓	✓
-	✓ ²	-	✓	-	✓	✓	✓
-	-	-	-	-	-	-	-
-	-	-	-	-	-	-	-
✓	✓ ²	✓	✓	✓	✓	✓	✓
-	✓	✓	✓	✓	✓	✓	✓
Piezo	Torque Motor	Torque Motor	Torque Motor	Torque Motor	Torque Motor	Torque Motor	Torque Motor
✓	✓	✓	✓	✓	✓	✓	✓
✓	✓	✓	✓	✓	✓	✓	✓
✓	✓	✓	✓	✓	✓	✓	✓
✓	✓	✓	✓	✓	✓	✓	✓
Potentiometer	Potentiometer	Potentiometer	Potentiometer	NCS Potentiometer	NCS Potentiometer	Potentiometer	Potentiometer
✓	✓	✓	✓	✓	✓	✓	✓
✓	-	-	-	-	-	-	-
-	-	-	-	-	-	✓	✓
IP66	IP66	IP66	IP66	IP66	IP66	IP66	IP66
-	NEMA 4X	-	NEMA 4X	NEMA 4X	NEMA 4X	NEMA 4X	NEMA 4X
Aluminium	Aluminium	Aluminium	STS316	Aluminium	STS316	Aluminium	STS316
✓	✓	✓	✓	✓	✓	✓	✓
✓	✓	✓	✓	✓	✓	✓	✓
✓	✓	✓	✓	✓	✓	✓	✓
-	✓	✓	✓	✓	✓	✓	✓
✓	✓	✓	✓	✓	✓	✓	✓
-	✓	✓	✓	✓	✓	-	-
-	✓	✓	✓	✓	✓	-	-
✓	-	-	-	-	-	✓	✓
Ver. 5	Ver. 7	Ver. 7	Ver. 7	Ver. 7	Ver. 7	Ver. 7	Ver. 7

Smart Positioner TMP-3000

Solenoid Technology

Design features

- **Vertical mounting.** Easy to mount installation.
- **Fail-freeze and fail-safe function.** Enables the valve maintain the last position (fail-freeze) or move to a pre-determined position (fail-safe) on the loss of electrical power supply or the pneumatic supply air.
- **LCD display.** Backlit alphanumeric digital display for process values and calibration.

- **Feedback signal.** 4 to 20 mA output option.
- **Auto calibration.** Simple menu structure with options to auto calibrate all parameters or zero and end points only.
- **Low air consumption level.** Almost zero air leakage.
- **Front panel pushbuttons for configuration.** Positive acting pushbuttons for field configuration.

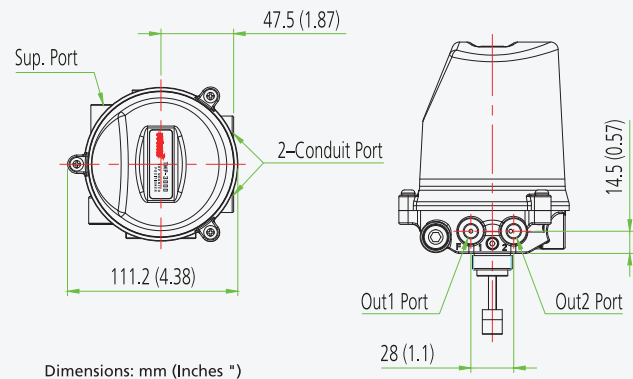

Item Type	TMP-3000
Power Supply	24 VDC ± 10%, DC 260mA(@21.6VDC)
Input Signal	0 to 20 mA, 4 to 20 mA, 0 to 5 V, 0 to 10 V
Power Consumption	< 5.8 W
Output	4 to 20 mA
Output Characteristics	Linear, EQ%, Quick Open, User Set(5 or 21 Points)
Operating Temp.	-10 to +50 °C (+14 to +122 °F)
Supply Pressure	0 to 0.7 MPa = 0 to 7 bar = 0 to 102 psi
Air Consumption	0 LPM (0 psi)
Flow Capacity	20 / 50 LPM (0.7 / 1.77 CFM)
Filtering Size	5 micron
Acting Type	Single 2 solenoid valves Double 4 solenoid valves
Stroke	5 to 40 mm (0.2 to 1.6")
Air Connection	G1/8 (Ø6 mm tube)
Conduit	2-M16 x 1.5P (with screw terminals)
Ingress Protection	IP67
Body Material	PPS
Cover Material	PC
Weight	750 g (1.7 lb)

Product Code

TMP-3000 - S - N - G - 1 - 0 - F

Model
TMP-3000 = Smart Positioner

Acting Type
S = Single
D = Double

Explosion Protection
N = Non-Explosion

Conduit & Air Connection
G = M16 x 1.5 - G1/8

Flow Capacity
1 = 20 LPM
2 = 50 LPM

Output Options
0 = None
1 = 4 to 20 mA feedback

Fail Option
F = Fail-freeze
S = Fail-safe

Pneumatic-Pneumatic Positioner YT-1200

Design features

- **Simple zero and span adjustment.** Internal hand dials and locking screws for 0.1 to 1 MPa range adjustments.
- **Reverse and direct acting settings.** Full and 1/2 split range setting by simple adjustment.
- **High vibration resistant.** No resonance between 5 to 200 Hz.
- **Auto / manual switch.** Internal adjustment with lock screw safety.



YT-1200 Aluminium Enclosure

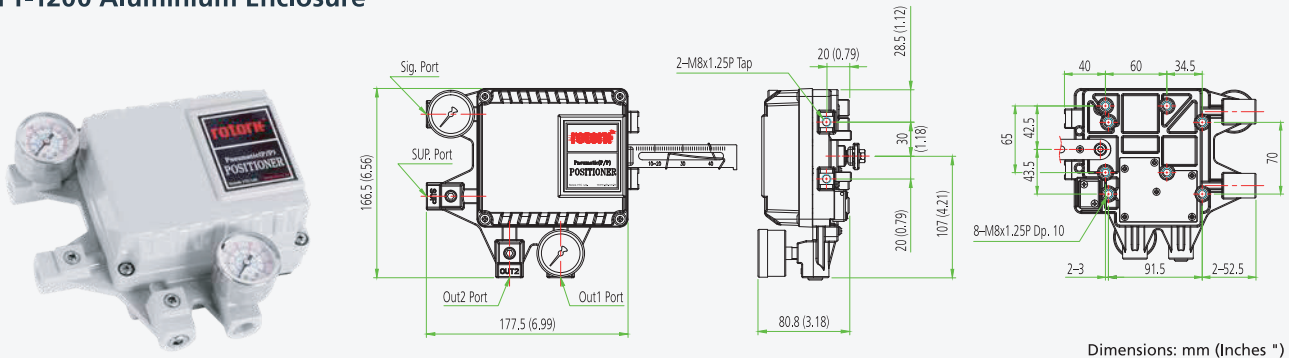

Dimensions: mm (Inches *)

Item Type	YT-1200L & YT-1200R	
	Single	Double
Input Signal	0.02 to 0.1 MPa=0.2 to 1 bar=3 to 14.5 psi	
Supply Pressure	0.14 to 0.7 MPa=1.4 to 7 bar=20 to 102 psi	
Stroke	Linear Type	10 to 150 mm (0.4 to 6")
	Rotary Type	55 to 100°
Air Connection	Rc 1/4, 1/4 NPT	
Gauge Connection	Rc 1/8, 1/8 NPT	
Ingress Protection	IP66	
Linearity	Linear Type	± 1% F.S.
	Rotary Type	± 2% F.S.
Hysteresis	±1% F.S.	
Sensitivity	Linear Type	± 0.2% F.S.
	Rotary Type	± 0.5% F.S.
Repeatability	± 0.5% F.S.	
Air Consumption	2.5 LPM (sup = 0.14 MPa) 0.08 CFM (sup = 20 psi)	
Flow Capacity	80 LPM (sup = 0.14 MPa) 2.83 CFM (sup = 20 psi)	
Material	Aluminium Diecasting	
Weight	1.7 kg (3.1 lb)	

Notes:
1. Only S, L of Operating Temperature is available
2. Only S of Operating Temperature is available

Product Code

YT-1200R - S - 1 - 1 - 2 - S - (0)

Model

YT-1200L = Linear Positioner
YT-1200R = Rotary Positioner

Acting Type

S = Single
D = Double

Lever Type

Linear	Rotary
1 = 10 to 40 mm	1 = M6 x 34L
2 = 30 to 70 mm	2 = M6 x 63L
3 = 60 to 100 mm	3 = M8 x 34L
4 = 100 to 150 mm	4 = M8 x 63L
	5 = NAMUR

Orifice Type

1 = Φ1
2 = Φ2
3 = None

Air Connection

1 = Rc 1/4
2 = 1/4 NPT

Operating Temp.

S = -20 to +70 °C (-4 to +158 °F)
H = -20 to +120 °C (-4 to +248 °F)
L = -40 to +70 °C (-40 to +158 °F)

Option (Rotary only)

0 = None
1 = Dome Cover
2 = 4 to 20 mA feedback - SPTM-5V (Non-explosion)¹
3 = 4 to 20 mA feedback - SPTM-6V (Flameproof enclosure)¹
4 = Limit switch - YT-850 (Non-explosion)²
5 = Limit switch - YT-870 (Flameproof enclosure)²
6 = 4 to 20 mA feedback + Limit Switch - YT-870 (Flameproof enclosure)²

Electro-Pneumatic Positioners YT-1000 / YT-1050

Design features

- **Simple zero and span adjustment.** Internal hand dials and locking screws for 4 to 20 mA range adjustments.
- **Reverse and direct acting settings.** Full and 1/2 split range setting by simple adjustment.
- **High vibration resistant.** No resonance between 5 to 200 Hz.
- **Internal feedback option.** Available on weatherproof model only.
- **Auto / manual switch.** Internal adjustment with lock screw safety.



YT-1000 Aluminium Enclosure

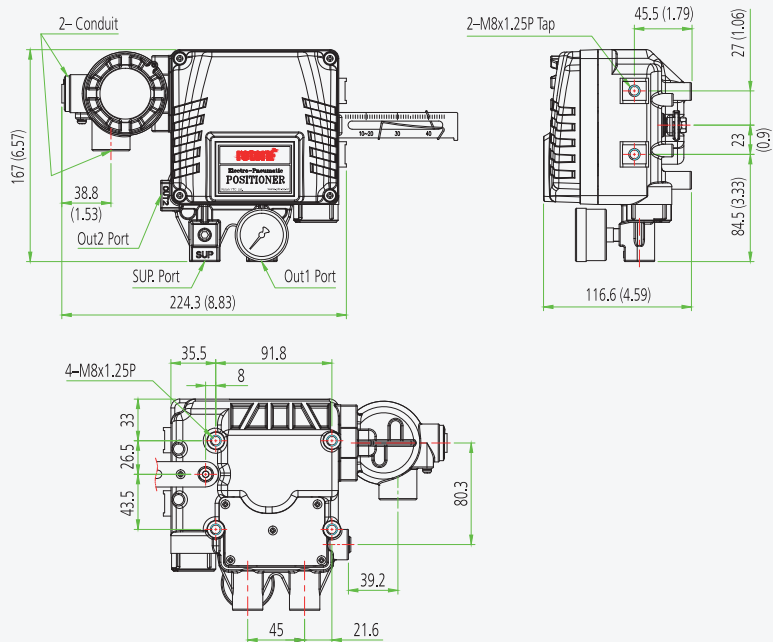

YT-1050 STS316 Enclosure

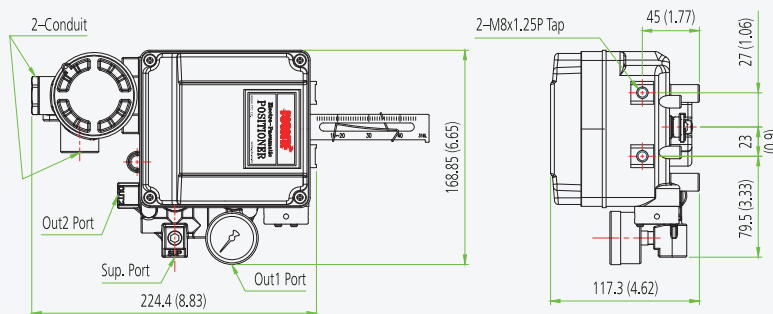

Dimensions: mm (Inches ")

Electro-Pneumatic Positioners YT-1000 / YT-1050

Item Type	YT-1000	YT-1050
Input Signal	4 to 20 mA DC	
Impedance	250 ± 15 Ω	
Supply Pressure	0.14 to 0.7 MPa = 1.4 to 7 bar = 20 to 102 psi	
Stroke	Linear Type	10 to 150 mm (0.4 to 6")
	Rotary Type	55 to 100°
Air Connection	Rc 1/4, 1/4 NPT, G 1/4	1/4 NPT
Gauge Connection	Rc 1/8, 1/8 NPT	1/8 NPT
Conduit	G(NPT)1/2, M20	G 1/2
Explosion Protection Type	ATEX, EAC, IECEx, INMETRO (II 2 G) Ex dmb IIB T5	
	KCs Ex dmb IIB T5/T4 / Ex d IIC T5 IP66 /	KCs Ex dmb IIB T5
	TS Ex db mb IIB T5 Gb X	-
	CSA (Class I, Zone 1) Ex dm IIB T5	-
	FM XP-S/I/1/CD/T5 Ta = +60 °C; DIP/II,III/1/EF/G/T5 Ta = +60 °C; Type 4X	-
	CCC Ex d mb IIB T5 Gb Ex d mb IIC T6 Gb Ex ia IIC T6 Ga	CCC Ex d mb IIB T5 Gb
	TIIS Ex dmb IIB T5	
Ingress Protection	YT-1000: IP66, TYPE 4X (FM) YT-1050: IP66	
Linearity	Single	± 1% F.S.
	Double	± 2% F.S.
Hysteresis	±1% F.S.	
Sensitivity	Single	± 0.2% F.S.
	Double	± 0.5% F.S.
Repeatability	± 0.5% F.S.	
Air Consumption	2.5 LPM (sup = 0.14 MPa) 0.8 CFM (sup = 20 psi)	
Flow Capacity	80 LPM (sup = 0.14 MPa) 2.83 CFM (sup = 20 psi)	
Material	Aluminium Diecasting	Stainless steel 316
Weight	YT-1000L: 2.7 kg (6.1 lb) YT-1000R: 2.8 kg (6.2 lb) YT-1050: 5.71 kg (12.6 lb)	

Product Code

YT-1000 - R - S - N - 1 - 1 - 4 - S - 0 - (0)

Model

YT-1000 = Aluminium
YT-1050 = STS316

Motion Type

L = Linear
R = Rotary

Acting Type

S = Single
D = Double

Explosion Protection¹

N = Non-Explosion
M² = Ex d m IIB, ATEX, IECEx, TS (YT-1000 only), KCs
A = CSA (YT-1000 only)
C = Ex d m IIC KCs (YT-1000 only)
E = Ex d EAC
X = TIIS (YT-1000 only)

T = Ex dm IIB INMETRO
Z = Ex dmb IIB T5 Gb CCC
B = Ex dmb IIC T6 Gb CCC (YT-1000 only)
G = Ex ia IIC T6 Ga CCC (YT-1000 only)
F = FM (YT-1000 only)

Lever Type

Linear	Rotary
1 = 10 to 40 mm	1 = M6 X 34L
2 = 30 to 70 mm	2 = M6 X 63L
3 = 60 to 100 mm	3 = M8 X 34L
4 = 100 to 150 mm	4 = M8 X 63L
	5 = NAMUR

Orifice Type

1 = Φ1
2 = Φ2
3 = None

Conduit & Air Connection

YT-1000	YT-1050
1 = G1/2 - Rc1/4	2 = G1/2 - 1/4 NPT (N/A for CCC)
2 = G1/2 - 1/4 NPT	5 = 1/2 NPT - 1/4 NPT (only CCC)
3 = G1/2 - G1/4	
4 = M20 - 1/4 NPT	
5 = 1/2 NPT - 1/4 NPT	

Operating Temp. (Non-explosionproof)³

S = -20 to +70 °C (-4 to +158 °F)
H = -20 to +120 °C (-4 to +248 °F)
L = -40 to +70 °C (-40 to +158 °F)

Option 1

YT-1000L	YT-1000R
0 = None	0 = None (St'd)
2 ⁴ = 4 to 20 mA feedback (Internal)	1 = Dome Cover
3 ⁴ = 4 to 20 mA feedback with LCD (Internal)	

Option 2 (YT-1000R only)

0 = None
1 = 4 to 20 mA feedback (Internal - only for non-explosion area protection)
2 = 4 to 20 mA feedback (External, SPTM-6V, Explosionproof)
3 = Limit Switch (Internal - only for non-explosion area protection)
4⁵ = Limit Switch (External, YT-850 (Non-explosion) or YT-870 (Explosionproof))
5 = 4 to 20 mA feedback + Limit Switch (Internal - only for non-explosion area protection)
6 = SPTM + Limit Switch (External, YT-870, Explosionproof)

Notes:

- Only S of Operating Temperature is available for M (except KCs of YT-1000), T, F, P, X, Z, B, G
Only S, H of Operating Temperature are available for M (only KCs of YT-1000)
Only S, L of Operating Temperature are available for A
Only L of Operating Temperature is available for E.
- Please put the name of the certificate in a purchase order.
- This option is just the normal operating temperature of the product and is not related to explosion protection temperature. See certificates for explosion protection temperature.
- Non-explosionproof.
- Please select one of between YT-850 and YT-870 and then put the name in a purchase order.

Smart Positioners YT-3300 / YT-3350 / YT-3301 / YT-3303

Torque motor technology with communications

Design features

- **Auto calibration.** Simple menu structure with options to auto calibrate all parameters or zero and end points only.
- **LCD display.** Alphanumeric digital display for process values and calibration.
- **Partial Stroke Test (PST).** Fully adjustable Partial Stroke Test. All functionality can be performed and selected locally, through push buttons, or remotely with communication protocol.
- **Feedback signal.** Analogue and digital feedback signals with 4 to 20 mA, mechanical and proximity switch options (Limit switch options for YT-3300 and YT-3350 models).
- **PID control.** Pre-calibrated and user configurable variables via front panel pushbutton menu.

- **Auto / Manual switch.** Enables closed-loop automatic valve position control or manual positioning via the A/M switch. The manual mode is useful for troubleshooting, calibration, system testing or as a manual bypass.
- **HART® communication.** Allows commands, position feedback and diagnostics to be sent digitally over the current loop.
- **Front panel pushbuttons for configuration.** Four robust and positive acting pushbuttons for field configuration.
- **Remote Mounting Option (YT-3301 model).** Remote sensor via cable to enable the positioner to be mounted away from extreme temperature.



YT-3300 Aluminium Enclosure

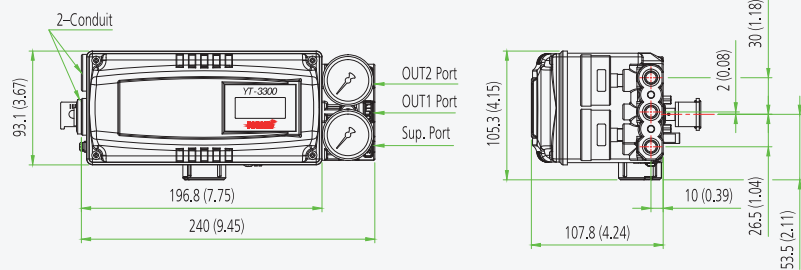

YT-3350 STS316 Enclosure

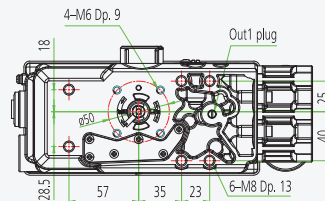

YT-3301 Remote Mounting Option

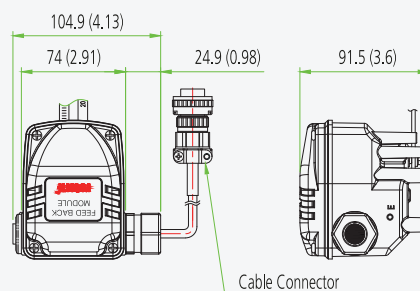

YT-3303 Left Side Mounting Option

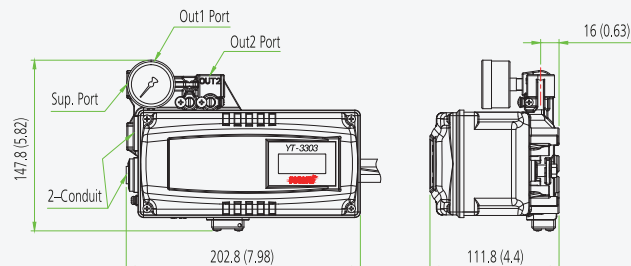

Dimensions: mm (Inches ")

Smart Positioners YT-3300 / YT-3303 / YT-3301 / YT-3350

Item Type	YT-3300	YT-3303	YT-3301	YT-3350	
Input Signal	4 to 20 mA DC				
Supply Pressure	0.14 to 0.7 MPa = 1.4 to 7 bar = 20 to 102 psi				
Stroke	Linear Type	10 to 150 mm (0.4 to 6")			
	Rotary Type	55 to 110°			
Impedance	Max. 500 Ω @ 20 mA DC				
Air Connection	Rc 1/4, 1/4 NPT, G 1/4		1/4 NPT		
Gauge Connection	Rc 1/8, 1/8 NPT		1/8 NPT		
Conduit	G 1/2, 1/2 NPT, M20x1.5P		G1/2		
Operating Temp.	Standard Type	-30 to +85 °C (-22 to +185 °F)			
	Low Temp. Type	-40 to +85 °C (-40 to +185 °F)			
	Arctic Temp. Type	-55 to +85 °C (-67 to +185 °F)			
	LCD	withstands -55 to +85 °C (-67 to +185 °F) only visible above -40 °C (-40 °F)			
Linearity	±0.5% F.S.				
Hysteresis	±0.5% F.S.				
Sensitivity	±0.2% F.S.				
Repeatability	±0.3% F.S.				
Air Consumption	Below 2 LPM (sup = 0.14 MPa) Below 0.08 CFM (sup = 20 psi)				
Flow Capacity	70 LPM (sup = 0.14 MPa) 2.47 CFM (sup = 20 psi)				
Output Characteristics	Linear, EQ%, Quick Open, User Set (5 or 18 Points)				
Material	Aluminium Diecasting	Aluminium Diecasting	Stainless Steel 316		
Ingress Protection	NEMA 4X, IP66	IP66	IP66, IP54	NEMA 4X, IP66	
Explosion Protection Type	ATEX, IECEx, EAC Ex ia IIC T5/T6 Gb, Ex ia IIIC T100°C/T85°C Db IP66 CCC Ex ia IIC T5/T6 Gb Ex iaD 21 T100/T85 KCs Ex ia IIC T5/T6, Ex iaD IIIC T100°C/T85°C CSA CSA certificate FM Class I, Div 1, Groups ABCD Class I, Zone 0 AEx ia IIC Class II/III, Div 1, Groups EFG Class I, II, III, Div 2, Groups ABCDEFG NEMA Type 4X, IP66, IP54 AMBIENT TEMP: -40 - 60°C (T5) / -40 - 40°C (T6) NEPSI (only YT-3300/3350) Ex ia IIC T5/T6 INMETRO Ex ia IIC T5/T6 Gb, Ex ia IIIC T100°C/T85°C Db				
Communication (Option)	HART (ver.7)				
L/S Rating	Mechanical Type (Omron)	AC 125 V, 3 A DC 30 V, 2 A	-	-	AC 125 V, 3 A DC 30 V, 2 A
	Proximity Type (P&F)	DC 8.2 V 8.2 mA	-	-	DC 8.2 V 8.2 mA
Weight	Body	2 kg (4.4 lb)	2.2 kg (4.9 lb)	5.1 kg (11.2 lb)	-
	Remote Sensor	-	-	1 kg (2.1 lb)	-

Product Code

YT-3300 - L - S - N - 2 - 4 - 2 - 4 - S - (1)

Model

YT-3300 = Aluminium housing
 YT-3303 = Aluminium housing with right side lever
 YT-3301 = Aluminium housing with remote sensor
 YT-3350 = Stainless steel housing

Motion Type

L = Linear
 R = Rotary

Acting Type

S = Single
 D = Double

Explosion Protection

N = Non-explosion
 i = Intrinsically Safe ATEX, IECEx, KCs, INMETRO, NEPSI
 E = Intrinsically Safe EAC
 A = Intrinsically Safe CSA, FM
 Z = Intrinsically Safe CCC

Lever Type

Linear YT-3300/3350	Rotary	fork type
0 = 10 to 40 mm	1 = M6 x 34L	
1 = 20 to 100 mm	2 = M6 x 63L	
2 = 90 to 150 mm	3 = M8 x 34L	
3 to 6 = Adapter type	4 = M8 x 63L	
Linear YT-3301/3303	5 = NAMUR (YT-3301)	
1 = 10 to 40 mm		
2 = 20 to 70 mm		
3 = 50 to 100 mm		
4 = 100 to 150 mm		

Conduit & Air Connection

1 = G1/2 - Rc1/4
 2 = G1/2 - 1/4 NPT (YT-3350 only available with conduit connection code 2)
 3 = G1/2 - G1/4
 4 = M20 - 1/4 NPT (YT-3303 and YT-3301 will come with electrical conduit adaptors)
 5 = 1/2 NPT - 1/4 NPT (YT-3303 and YT-3301 will come with electrical conduit adaptors)

Communications

0 = None
 2 = HART protocol communication
 3 = Profibus PA communication protocol (only YT-3300/3350)
 4 = Foundation Fieldbus (only YT-3300/3350)

Output Options

0 = None
 1 = 4 to 20 mA feedback
 2¹ = Limit Switch - Mechanical Type (YT-3300 and YT-3350 only)
 3² = Limit Switch - Proximity Type (YT-3300 and YT-3350 only)
 4¹ = 4 to 20 mA + Limit Switch - Mechanical Type (YT-3300 and YT-3350 only)
 5² = 4 to 20 mA + Limit Switch - Proximity Type (YT-3300 and YT-3350 only)

Operating Temp. (Non-explosionproof)³

S = -30 to +85 °C (-22 to +185 °F) (N/A for EAC)
 L = -40 to +85 °C (-40 to +185 °F)
 A = -55 to +85 °C (-67 to +185 °F) (only available with EAC certification)

Cable Length (YT-3301 only)

Option for YT-3301 only. Standard cable length is 5 m.
 1 = 5 m
 2 = 10 m
 3 = 15 m
 4 = 20 m

Notes:

1. Only S, L of Operating Temperature are available for 2, 4 of Output Options.
2. Only S of Operating Temperature is available for 3, 5 of Output Options.
3. This option is just the normal operating temperature of the product and is not related to explosion protection temperature. See certificates for explosion protection temperature.

Smart Positioners YT-3700 / YT-3750

Digital smart positioner with enhanced diagnostics

Design features

- Enhanced diagnostic** (including offline and online) to fully check the integrity of the system. Valve signature, advanced step tests and Partial Stroke Testing (PST) can be operated from local or remote positions. Device Description (DD) and Device Type Manager (DTM) files allow for full software compatibility.
- Visual diagnostic info** to NE107 standard for a user-friendly analysis with a severity alarm scale and a clear visual identification locally on the display or remotely through HART®.
- Digital input/output configurable** depending on the application and customer preferences. Multiple options are available e.g. start a pre-set PST event or receive error alarms, tailoring interaction with the device as necessary.
- Auto tuning** functionality.
- Non-contact sensor** for increased performance for high frequency operating valves and an enhanced lifetime.



YT-3700 Aluminium Enclosure

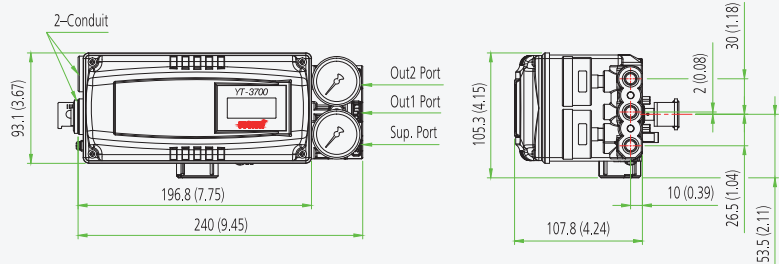

YT-3700 Aluminium Enclosure With Limit Switches and Dome Indicator

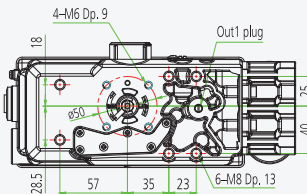

YT-3750 STS316 Enclosure



Dimensions: mm (Inches ")

Smart Positioners YT-3700 / YT-3750

Online diagnostics

These digital smart positioners employ continuous monitoring and graphic display of valve position, set point target vs time and internal circuit board temperature vs time.

Steady state deviation online analysis can detect:

- Friction in the valve or actuator
- Leakage in pneumatics
- Insufficient supply pressure

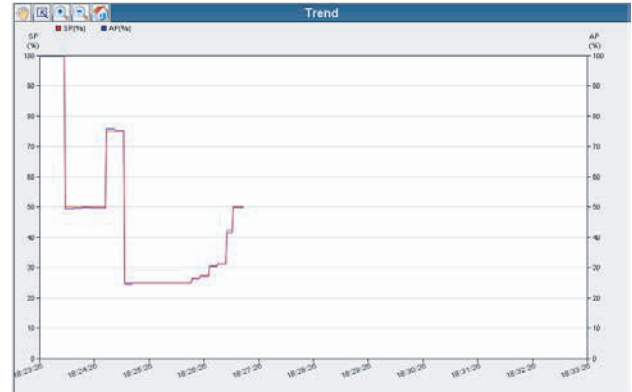

A deviation time out alarm occurs when the difference between the target position and the actual position exceeds the preset deviation alarm point (for more than the preset deviation time).

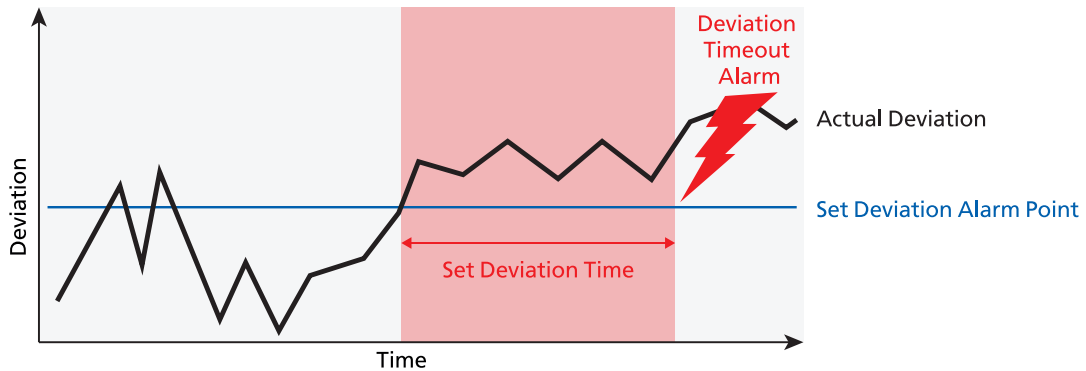

Alarms

An embedded memory in the YT-3700 series can store up to 11 PST test results and up to 20 alarm logs. Through DTM, the history of files will be easy to detect and the valve system integrity easily verified.

Examples of YT-3700 user configurable alarm/status based on NE107 status signal:

- Critical NVM failure
- Travel sensor failure
- RAM defect
- Drive Signal
- Temperature signal
- Deviation
- Travel accumulator
- Cycle counter
- Full close/open count
- PST failure
- Auto calibration failure

Note: Alarm severity can be set by operator

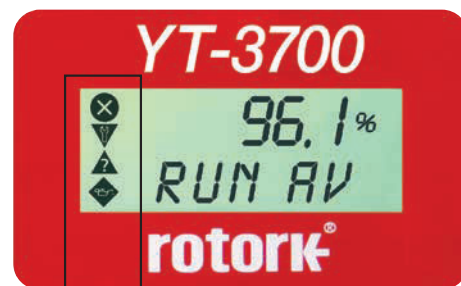

	Failure High severity
	Check function Signal temporarily invalid
	Out of specification Medium severity
	Maintenance required Low severity

Explanation of on-screen icons

Offline diagnostics

Automated package tests, checking integrity and dynamic behavior:

- Valve signature
- 25% step test
- Large step test
- Performance step test

These tests provide data to validate system performances. The system allows a reference to be set for further analysis highlighting performance shifts for predictive maintenance.

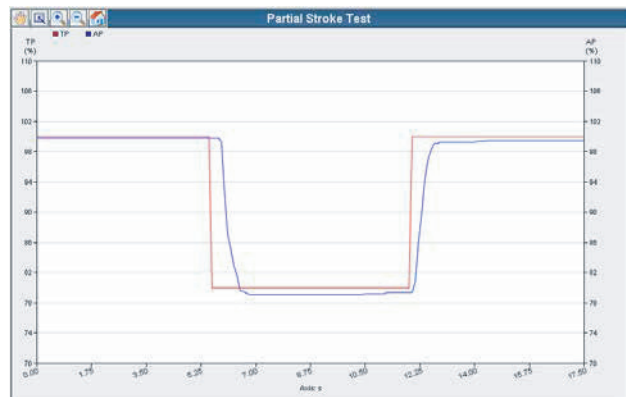
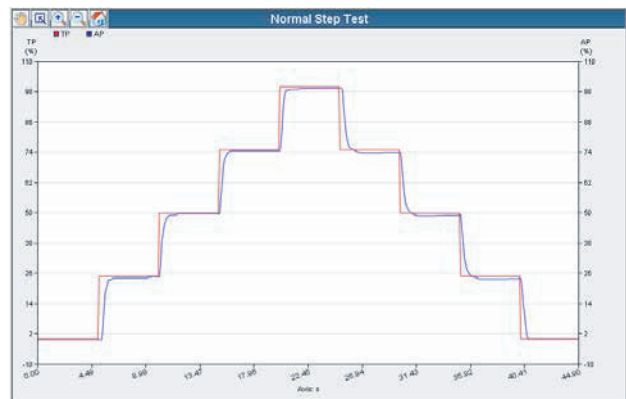
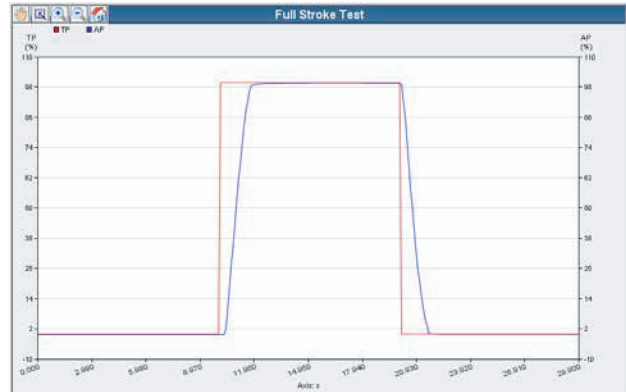

Partial Stroke Test capabilities

Automated PST functionality:

Configurable parameters

- PST interval [days]
- Position tolerance [%]
- PST start position [%]
- Target position [%]
- PST time out limit [sec]
- Target position hold time [sec]
- PST ramp up/down [%/sec] to reduce risks of overshooting system

Test activation via:

- Local positioner menu
- Remote DI control push button
- Remote HART® connection

Smart Positioners YT-3700 / YT-3750

Item Type	YT-3700	YT-3750
Input Signal	4 to 20 mA DC	
Supply Pressure	0.14 to 0.7 MPa = 1.4 to 7 bar = 20 to 102 psi	
Stroke	Linear Type	10 to 150 mm (0.4 to 6")
	Rotary Type	55 to 110°
Impedance	Max. 500 Ω @ 20 mA DC	
Air Connection	Rc1/4, 1/4NPT, G1/4	1/4NPT
Gauge Connection	Rc1/8, 1/8NPT	1/8NPT
Conduit	G1/2, M20, 1/2NPT	G1/2
Operating Temp.	Standard Type	-30 to +85 °C (-22 to +185 °F)
	Low Temp. Type	-40 to +85 °C (-40 to +185 °F)
	Arctic Temp. Type	-55 to +85 °C (-67 to +185 °F)
	LCD	withstands -55 to +85 °C (-67 to +185 °F) only visible above -40 °C (-40 °F)
Linearity	±0.5% F.S.	
Hysteresis	±0.5% F.S.	
Sensitivity	±0.2% F.S.	
Repeatability	±0.3% F.S.	
Air Consumption	Below 2 LPM (sup = 0.14 Mpa) Below 0.07 CFM (sup = 20 psi)	
Flow Capacity	70 LPM (sup = 0.14 MPa) 2.47 CFM (sup = 20 psi)	
Output Characteristics	Linear, EQ%, Quick Open, User Set (5 or 21 Points)	
Material	Aluminium Diecasting	Stainless Steel 316
Ingress Protection	Ip66, Type 4x	
Explosion Protection Type	ATEX / IECEx Ex ia IIC T5/T6 Gb Ex ia IIIC T100°C/T85°C Db IP 6x	
	CCC	Ex ia IIC T5/T6 Gb Ex iaD 21 T100/T85
	KCs	Ex ia IIC T6/T5 Ex ia IIIC T85°C/T100°C
	FM	Intrinsically Safe. See the product manual for the detail.
	CSA	Intrinsically Safe. See the product manual for the detail.
	INMETRO	Ex ia IIC T6/T5 Gb Ex ia IIC T85°C/T100°C Db IP66
	NEPSI	Ex ia IIC T5/T6 Gb, Ex iaD 21 T100/T85
	EAC	Intrinsically Safe. See the product manual for the detail.
Communication (Option)	HART (ver.7)	
L/S Rating	Mechanical Type (Omron)	AC 125 V, 3 A / DC 30 V, 2 A
	Proximity Type (P&F)	DC 8.2 V 8.2 mA
Weight	2 kg (4.4 lb)	5.1 kg (11.2 lb)
Digital Input	Low level control voltage 0 to 5 VDC High level control voltage 11 to 28 VDC Max current < 4 mA	
Digital Output	Supply voltage 5 to 28 VDC Low level current < 1 mA High level current > 2.1 mA @5 VDC, < 14mA @28 VDC	

Product Code

YT-3700 - L - S - N - 2 - 4 - 2 - 4 - S

Model

YT-3700 = Aluminium housing
YT-3750 = Stainless steel housing

Motion Type

L = Linear
R = Rotary (in case of a switches request the device will have visual position indicator as standard)

Acting Type

S = Single
D = Double

Explosion Protection

N = Non-explosion
i = Intrinsically Safe ATEX, IECEx.KCs
A = Intrinsically Safe CSA, FM (Both S and L of Operating Temp. available.)
E = Intrinsically Safe EAC
Z = Intrinsically Safe CCC

Lever Type

Linear Rotary
0 = 10 to 40 mm 5 = NAMUR
1 = 20 to 100 mm
2 = 90 to 150 mm

Conduit & Air Connection

1 = G1/2 - Rc1/4
2 = G1/2 - 1/4 NPT (YT-3750 is available for No. 2 ONLY)
3 = G1/2 - G1/4
4 = M20 - 1/4 NPT
5 = 1/2 NPT - 1/4 NPT

Communication Protocols

2 = HART communication

Output Options

0 = None
1 = 4 to 20 mA feedback
4¹ = 4 to 20 mA feedback + Limit Switch - Mechanical Type (potentiometer drive without digital I/O communication)
5² = 4 to 20 mA feedback + Limit Switch - Proximity Type (potentiometer drive without digital I/O communication)

Operating Temp. (Non-explosion proof)³

S = -30 to +85 °C (-22 to +185 °F) (N/A for EAC)
L = -40 to +85 °C (-40 to +185 °F)
A = -55 to +85 °C (-67 to +185 °F) (only available with EAC certification)

Notes:

1. Only S, L of Operating Temperature are available for 4 of Output Options
2. Only S of Operating Temperature is available for 5 of Output Options
3. This option is just the normal operating temperature of the product and is not related to explosion protection temperature. See certificates for explosion protection temperature.

Smart Positioners YT-3400 / YT-3450

Torque motor technology with communications

Design features

- **Explosionproof / flameproof housing.** Global certification for Zone 1 and Division 1 installations.
- **Auto calibration.** Simple menu structure with options to auto calibrate all parameters or zero and end points only.
- **LCD display.** Alphanumeric digital display for process values and calibration.
- **Partial Stroke Test (PST).** Fully adjustable PST, with single or double set positions, all functionality can be performed and selected locally, through push buttons, or remotely with communication protocol.
- **Feedback signal.** Analogue feedback signals with 4 to 20 mA, mechanical and transistor switch options.

- **Auto / manual switch.** Enables closed-loop automatic valve position control or manual positioning via the Open / Close buttons. The manual mode is useful for troubleshooting, calibration, system testing or as a manual bypass.
- **PID control.** Pre-calibrated and user configurable variables via front panel pushbutton menu.
- **HART® communication.** Allows commands, position feedback and diagnostics to be sent digitally over the current loop.
- **Front panel pushbuttons for configuration.** Four robust and positive acting pushbuttons for field configuration.



YT-3400 Aluminium Enclosure

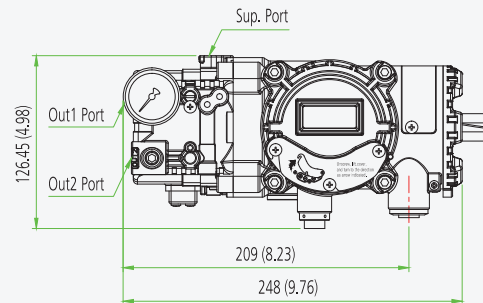

YT-3450 STS316 Enclosure

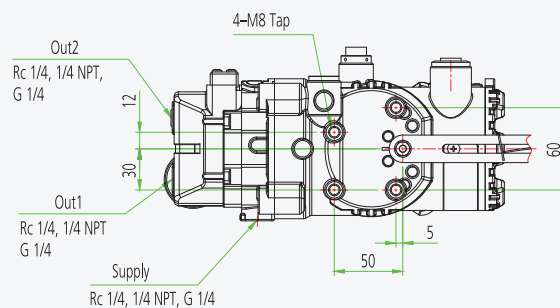
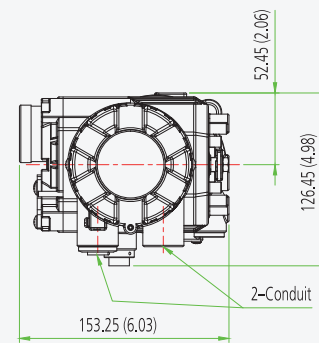
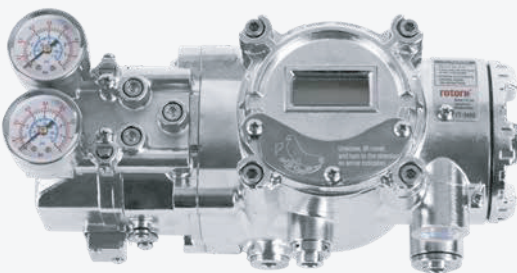

Dimensions: mm (Inches ")

Smart Positioners YT-3400 / YT-3450

Item Type	YT-3400	YT-3450
Input Signal	4 to 20 mA DC	
Supply Pressure	0.14 to 0.7 MPa = 1.4 to 7 bar = 20 to 102 psi	
Stroke	Linear Type	10 to 150 mm (0.4 to 6")
	Rotary Type	55 to 110°
Impedance	Max. 450 Ω @ 20 mA DC	
Air Connection	Rc 1/4, 1/4 NPT, G 1/4	1/4 NPT
Gauge Connection	Rc 1/8, 1/8 NPT	1/8 NPT
Conduit	G 1/2, 1/2 NPT, M20	G 1/2
Operating Temp.	Standard Type	-30 to +85 °C (-22 to +185 °F)
	Low Temp. Type	-40 to +85 °C (-40 to +185 °F)
	Arctic Temp. Type	-55 to +85 °C (-67 to +185 °F)
	LCD Operating Temp.	withstands -55 to +85 °C (-67 to +185 °F) only visible above -40 °C (-40 °F)
Linearity	±0.5% F.S.	
Hysteresis	±0.5% F.S.	
Sensitivity	±0.2% F.S.	
Repeatability	±0.3% F.S.	
Air Consumption	Below 2 LPM (sup = 0.14 MPa) Below 0.08 CFM (sup = 20 psi)	
Flow Capacity	70 LPM (sup = 0.14 MPa) 2.47 CFM (sup = 20 psi)	
Output Characteristics	Linear, EQ%, Quick Open, user set (5 or 18 Points)	
Material	Aluminium Diecasting	Stainless Steel 316
Ingress Protection	NEMA 4-4X, IP66	
Explosion Protection Type	ATEX, IECEx, EAC Ex db IIC T5/T6, Ex tb IIIC T85°C/T100°C CCC, NEPSI Ex d IIC T5/T6 Gb Ex tD A21 IP66 T85°C/T100°C KCs Ex d IIC T5/T6 IP66 CSA Ex db IIC T5 or T6 Class I, Zone 1, AEx db IIC T5 or T6, Class II, Division 1, Groups E, F and G; Ex tb IIC T85°C/T100°C AEx tb IIIC T85°C/T100°C Type 4, 4X; IP66 FM XP/V1/ABCD/T6 Ta= -40°C to +70°C, T5 Ta= -40°C to +80°C I1/AEx db IIC/T6 Ta= -40°C to +70°C, T5 Ta= -40°C to +80°C DIP/II, III/1/EFG/T6 Ta= -40°C to +70°C, T5 Ta= -40°C to +80°C 21/AEx tb IIIC/T85°C Ta= -40°C to +70°C, T100°C Ta= -40°C to +80°C; IP66 ECAS Ex db IIC T5/T6 Gb, Ex tb IIIC T100°C/T85°C Db INMETRO Ex db IIC T5/T6 Gb IP66 Ex tb IIIC T85°C/T100°C Db IP66	
Communication (Option)	HART (ver.7)	
Weight	3.4 kg (7.5 lb)	7.0 kg (15.4 lb)

Product Code

YT-3400 - L - S - C - 2 - 4 - 2 - 3 - S

Model

YT-3400 = Aluminium housing
YT-3450 = Stainless steel housing

Motion Type

L = Linear
R = Rotary

Acting Type

S = Single
D = Double

Explosion Protection

C¹ = ATEX, IECEx, KCs, CCC, NEPSI, INMETRO
E = EAC
A = CSA, FM
Z = CCC

Lever Type

Linear	Rotary
1 = 10 to 40 mm	1 = M6 x 34L
2 = 20 to 70 mm	2 = M6 x 63L
3 = 50 to 100 mm	3 = M8 x 34L
4 = 100 to 150 mm	4 = M8 x 63L
	5 = NAMUR

Conduit & Air Connection

1 = G1/2 - Rc1/4 (N/A for CCC, YT-3450)
2 = G1/2 - 1/4 NPT (N/A for CCC)
3 = G1/2 - G1/4 (N/A for CCC, YT-3450)
4 = M20 - 1/4 NPT (N/A for YT-3450)
5 = 1/2 NPT - 1/4 NPT

Communication

0 = None
2 = HART protocol communication

Output Options

0 = None
1 = 4 to 20 mA feedback
2 = Limit switch²
3 = 4 to 20 mA feedback + Limit switch²

Operating Temp. (Non-explosion proof)³

S = -30 to +85 °C (-22 to +185 °F) (N/A for EAC)
L = -40 to +85 °C (-40 to +185 °F)
A = -55 to +85 °C (-67 to +185 °F) (only available with EAC certification)

Notes:

1. Please put the name of the certificate in a purchase order.
2. Limit switch: DC 24V (50mA) and transistor type.
3. This option is just the normal operating temperature of the product and is not related to explosion protection temperature. See certificates for explosion protection temperature.

Smart Positioners YT-2500 / YT-2550 / YT-2501

Piezo technology with communications

Design features

- **Fail-freeze and fail-safe functions.** Enables the valve maintain the last position (fail-freeze) or move to a pre-determined position (fail-safe) on the loss of electrical power supply or the pneumatic supply air.
- **Auto calibration.** Simple menu structure with options to auto calibrate all parameters or zero and end points only.
- **LCD display.** Alphanumeric digital display for process values and calibration.
- **Low air consumption level.** Almost zero air leakage.
- **Feedback signal.** Analogue feedback signals with 4 to 20 mA, mechanical and proximity switch options.
- **PD control.** Pre-calibrated and user configurable variables via front panel pushbutton menu.
- **HART® communication.** Allows commands, position feedback and diagnostics to be sent digitally over the current loop.
- **Front panel pushbuttons for configuration.** Four robust and positive acting pushbuttons for field configuration.



YT-2500 Aluminium Enclosure

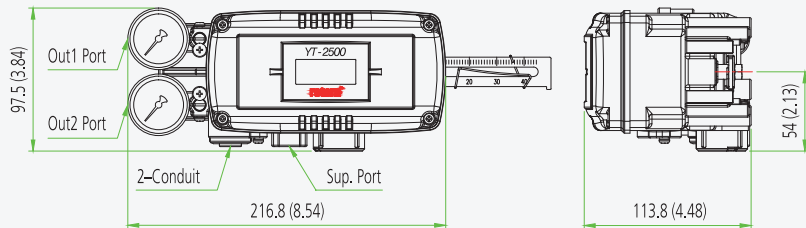

YT-2550 Stainless Steel Enclosure

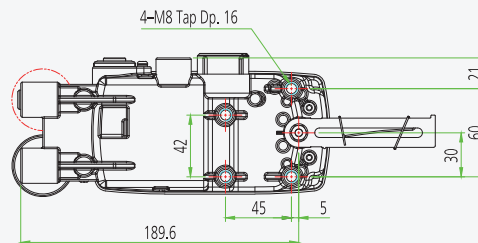

YT-2501 Remote Mounting Option

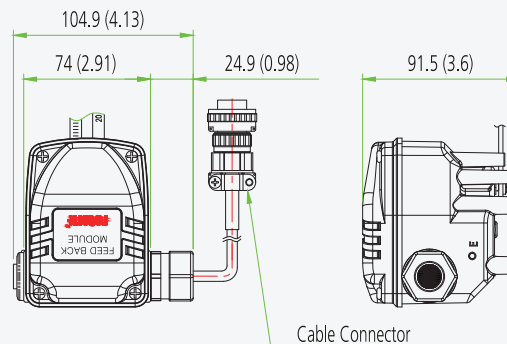

Dimensions: mm (Inches ")

Smart Positioners YT-2500 / YT-2550 / YT-2501

Item Type	YT-2500	YT-2550	YT-2501	
Input Signal	4 to 20 mA DC			
Supply Pressure	0.14 to 0.7 MPa = 1.4 to 7 bar = 20 to 102 psi			
Stroke	Linear Type	10 to 150 mm (0.4 to 6")		
	Rotary Type	55 to 110°		
Impedance	Max. 500 Ω @ 20 mA DC			
Air Connection	Rc 1/4, 1/4 NPT, G 1/4	1/4 NPT	Rc 1/4, 1/4 NPT, G 1/4	
Gauge Connection	Rc 1/8, 1/8 NPT	1/8 NPT	Rc 1/8, 1/8 NPT	
Conduit	G 1/2, 1/2 NPT, M20x1.5P	G 1/2	G 1/2, 1/2 NPT, M20x1.5P	
Operating Temp.	Standard Type	-30 to +80 °C (-22 to +176 °F) ¹		
	Explosion Temp.	-30 to +60 °C (-22 to +140 °F) (T5) -30 to +40 °C (-22 to +104 °F) (T6)		
	Remote Sensor	-	-40 to +120 °C (-40 to +248 °F)	
Linearity	±0.5% F.S.			
Hysteresis	±0.5% F.S.			
Sensitivity	±0.2% F.S.			
Repeatability	±0.3% F.S.			
Air Consumption	Fail-freeze	0.01 LPM (sup = 0.14 MPa) 0 CFM (sup = 20 psi)		
	Fail-safe	0.06 LPM (sup = 0.14 MPa) 0.002 CFM (sup = 20 psi)		
Flow Capacity	Fail-freeze	60 LPM (sup = 0.14 MPa) 2.12 CFM (sup = 20 psi)		
	Fail-safe	40 LPM (sup = 0.14 MPa) 1.41 CFM (sup = 20 psi)		
Output Characteristics	Linear, EQ%, Quick Open, User Set (5 or 18 Points)			
Material	Aluminium Diecasting	Stainless Steel 316	Aluminium Diecasting	
Ingress Protection	IP66			
Explosion Protection Type	ATEX, IECEx Ex ia IIC T5/T6 Gb, Ex ia IIIC T85°C/T100°C IP6X			
	CCC Ex ia IIC T5/T6 Gb Ex iaD 21 T100/T85			
	KCs Ex ia IIC T5/T6, EX iaD IIIC T100°C/T85°C			
	NEPSI (only YT-2500) Ex ia IIC T5/T6 Gb Ex iaD 21 T100/T85			
	EAC (only YT-2500) 1Ex ia IIC T6...T5 Gb X Ex ia IIIC T85°C...T100°C Db X IP66			
Communication (Option)	HART (ver.5)			
L/S Rating	Mechanical Type (Omron)	AC 125 V, 3 A DC 30 V, 2 A	-	
	Proximity Type (P&F)	DC 8.2 V 8.2 mA	-	
Weight	Body	1.5 kg (3.3 lb)	2.9 kg (6.4 lb)	1.6 kg (3.4 lb)
	Linear Remote sensor	-	-	0.6 kg (1.3 lb)
	Rotary Remote sensor	-	-	1.0 kg (2.1 lb)

Product Code

YT-2501 - L - S - N - 2 - 4 - 2 - 3 - S - (1)

Model

YT-2500 = Aluminium housing
YT-2550 = Stainless steel house
YT-2501 = Aluminium housing with remote sensor

Motion Type

L = Linear
R = Rotary

Acting Type

S = Single
D = Double

Explosion Protection

N = Non-Explosion
i = ATEX, IECEx, KCs, NEPSI (only YT-2500)
E = EAC (only YT-2500)
Z = CCC

Lever Type

Linear	Rotary
1 = 10 to 40 mm	1 = M6 x 34L
2 = 20 to 70 mm	2 = M6 x 63L
3 = 50 to 100 mm	3 = M8 x 34L
4 = 100 to 150 mm	4 = M8 x 63L
	5 = NAMUR (YT-2501)

Conduit & Air Connection

1 = G1/2 - Rc1/4
2 = G1/2 - 1/4 NPT (YT-2550 only available with conduit connection code 2)
3 = G1/2 - G1/4
4 = M20-1/4 NPT (YT-2501 will come with electrical conduit adaptors)
5 = 1/2 NPT-1/4 NPT (YT-2501 will come with electrical conduit adaptors)

Communications

0 = None
2 = HART protocol communication

Output Options

0 = None
1 = 4 to 20 mA feedback
2 = Limit switch - Mechanical Type (YT-2500 and YT-2550 only)
3 = Limit switch - Proximity Type (YT-2500 and YT-2550 only)¹
4 = 4 to 20 mA feedback + Limit switch - Mechanical Type (YT-2500 and YT-2550 only)
5 = 4 to 20 mA feedback + Limit switch - Proximity Type (YT-2500 and YT-2550 only)¹

Fail Option

F = Fail-freeze
S = Fail-safe

Cable Length (YT-2501 only)

Option for YT-2501 only. Standard cable length is 5 m.
1 = 5 m
2 = 10 m
3 = 15 m
4 = 20 m

Notes:

1. Inductive proximity limit switch internal type: -25 to +80 °C (-13 to 176 °F).

Smart Positioner YT-2600

Piezo technology with communications

Design features

- **Fail-freeze and fail-safe functions.** Enables the valve maintain the last position (fail-freeze) or move to a pre-determined position (fail-safe) on the loss of electrical power supply or the pneumatic supply air.
- **Explosionproof / flameproof housing.** Global certification for Zone 1 and Division 1 installations
- **Auto calibration.** Simple menu structure with options to auto calibrate all parameters or zero and end points only.
- **LCD display.** Alphanumeric digital display for process values and calibration.
- **Low air consumption level.** Almost zero air leakage.
- **Feedback signal.** Analogue feedback signals with 4 to 20 mA, transistor switch options.
- **PD control.** Pre-calibrated and user configurable variables via front panel pushbutton menu.
- **HART® communication.** Allows commands, position feedback and diagnostics to be sent digitally over the current loop.
- **Front panel pushbuttons for configuration.** Four robust and positive acting pushbuttons for field configuration.



YT-2600 Aluminium Ex d Positioner

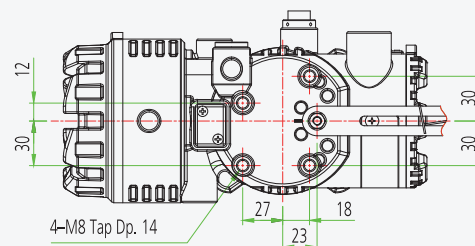
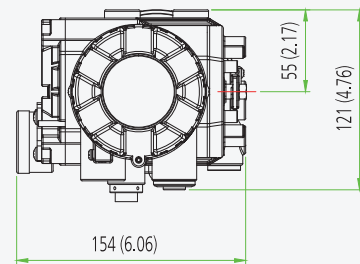
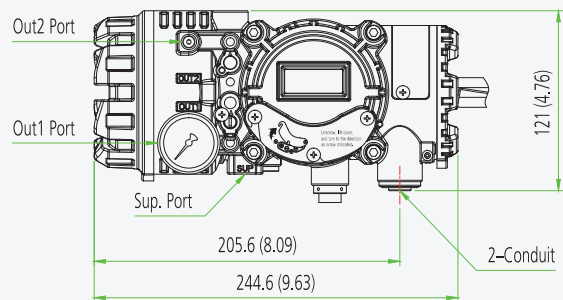

Dimensions: mm (Inches ")

Smart Positioner YT-2600

Item Type	YT-2600	
Input Signal	4 to 20 mA DC	
Supply Pressure	0.14 to 0.7 MPa = 1.4 to 7 bar = 20 to 102 psi	
Stroke	Linear Type	10 to 150 mm (0.4 to 6")
	Rotary Type	0 to 90°
Impedance	Max. 450 Ω @ 20 mA DC	
Air Connection	Rc 1/4, 1/4 NPT, G 1/4	
Gauge Connection	Rc 1/8, 1/8 NPT	
Conduit	G 1/2, 1/2 NPT, M20x1.5P	
Operating Temp.	Standard Type	-30 to +80 °C (-22 to +176 °F)
	Explosion Temp.	-30 to +80 °C (-22 to +176 °F) (T5) -30 to +70 °C (-22 to +158 °F) (T6)
Linearity	±0.5% F.S.	
Hysteresis	±0.5% F.S.	
Sensitivity	±0.2% F.S.	
Repeatability	±0.3% F.S.	
Air Consumption	Fail-freeze	0.01 LPM (sup = 0.14 MPa) 0 CFM (sup = 20 psi)
	Fail-safe	0.06 LPM (sup = 0.14 MPa) 0.002 CFM (sup = 20 psi)
Flow Capacity	Fail-freeze	50 LPM (sup = 0.14 MPa) 1.77 CFM (sup = 20 psi)
	Fail-safe	40 LPM (sup = 0.14 MPa) 1.41 CFM (sup = 20 psi)
Output Characteristics	Linear, EQ%, Quick Open, User Set (5 or 18 Points)	
Material	Aluminium Diecasting	
Ingress Protection	IP66	
Explosion Protection Type	ATEX, IECEx, KCs Ex db IIC T5/T6, Ex tb IIIC T85°C/T100°C EAC 1Ex d IIC T6/T5 Gb X Ex tb IIIC T85°C/T100°C Db X IP66	
	CCC Ex d IIC T5/T6 Gb Ex tD A21 IP66 T85°C/T100°C	
	EAC 1Ex d IIC T6...T5 Gb X Ex tb IIIC T85°C...T100°C Db X IP66	
Communication (Option)	HART (ver.5)	
Weight	3.0 kg (6.61 lb)	

Product Code

YT-2600 - L - S - C - 2 - 4 - 2 - 3 - S

Model

YT-2600 = Aluminium housing

Motion Type

L = Linear
R = Rotary

Acting Type

S = Single
D = Double

Explosion Protection

C = ATEX, IECEx, KCs E = EAC
Z = CCC

Lever Type

Linear	Rotary
1 = 10 to 40 mm	1 = M6 x 34L
2 = 20 to 70 mm	2 = M6 x 63L
3 = 50 to 100 mm	3 = M8 x 34L
4 = 100 to 150 mm	4 = M8 x 63L
	5 = NAMUR

Conduit & Air Connection

1 = G1/2 - Rc1/4 (N/A for CCC)
2 = G1/2 - 1/4 NPT (N/A for CCC)
3 = G1/2 - G1/4 (N/A for CCC)
4 = M20x1.5P - 1/4 NPT
5 = 1/2 NPT - 1/4 NPT

Communications

0 = None
2 = HART protocol communication

Output Options

0 = None
1 = 4 to 20 mA feedback
2 = Limit switch¹
3 = 4 to 20 mA feedback + Limit switch¹

Fail Option

F = Fail-freeze
S = Fail-safe

Notes:

1. Limit switch: DC 24V (50mA) and transistor type.

IP Converters YT-930 / YT-940

Design features

- **Flameproof housing (YT-940)** for Zone 1 installation.
- **High accuracy and sensitivity** with pressure sensor.
- **Analogue PID control.** High resolution proportional control
- **No effect from mounting orientation**

Item Type	YT-930	YT-940
Input Signal	4 to 20 mA DC	
Output Pressure	Standard	1 0.02 ~ 0.1 MPa (0.2 ~ 1.0 bar)
	Multi-range	2 0.00 ~ 0.12 MPa (0 ~ 1.2 bar)
		3 0.04 ~ 0.2 MPa (0.4 ~ 2.0 bar)
		4 0.00 ~ 0.23 MPa (0 ~ 2.3 bar)
Supply Pressure	Standard	1 0.13 ~ 0.16 MPa (1.3 ~ 1.6 bar)
	Multi-range	2 0.14 ~ 0.16 MPa (1.4 ~ 1.6 bar)
		3 0.22 ~ 0.24 MPa (2.2 ~ 2.4 bar)
		4 0.25 ~ 0.27 MPa (2.5 ~ 2.7 bar)
Explosion Protection Type	ATEX, IECEx Ex ia IIC T5/T6 Gb, Ex ia IIC T100°C/ T85°C Db	FM, CSA Class I Division 1 Groups A,B,C,D Class II, III Division 1 Groups E,F,G Class I Zone 1 AEx d IIC T6 Ta=-40°C to +75°C, T5 Ta=-40°C to +85°C, Type 4X, IP66 Zone 21 AEx tb IIC T85°C Ta= -40°C to +75°C, T100°C Ta= -40°C to +85°C, Type 4X, IP66 KCs Ex d IIC T5/T6
Air Consumption	Below 2 LPM (sup = 0.14 MPa) Below 0.08 CFM (sup = 20 psi)	
Flow Capacity	70 LPM (sup = 0.14 MPa) 2.47 CFM (sup = 20 psi)	
Explosion Temp.	-40 to +60 °C (T5) / -40 to +40 °C (T6)	-40 to +85 °C (T5) / -40 to +75 °C (T6)
Operating Temp.	-40 to +85 °C (-22 to +185 °F)	
Linearity	±0.5% F.S.	
Hysteresis	±0.5% F.S.	
Sensitivity	±0.2% F.S.	
Repeatability	±0.3% F.S.	
Air Connection	Rc 1/4, 1/4 NPT	
Conduit	G 1/2	
Ingress Protection	IP66	Type 4X, IP66
Impedance	Max. 390Ω @20mA DC	Max. 390Ω @20mA DC
Material	Aluminium Diecasting	
Weight	1.6 kg (3.53 lb)	2.5 kg (5.6 lb)



YT-930

YT-940



Product Code

YT-930 - N - 1 - 1 - L - 0 - 0

Model

YT-930 = Intrinsically Safety Type
YT-940 = Flameproof Type

Explosion Protection

YT-930
N = Non-Explosion
i = ATEX, IECEx

YT-940
C = KCs, FM, CSA

Output Pressure

1 = 0.02 to 0.1 MPa
2 = 0.00 to 0.12 MPa
3 = 0.04 to 0.2 MPa
4 = 0.00 to 0.23 MPa

Conduit - Air Connection

1 = G1/2 - Rc1/4
2 = G1/2 - 1/4 NPT

Operating Temp. (Non-explosionproof)¹

L = -40 to +85 °C (-40 to +185 °F)

Option

0 = None
1 = Feedback Signal (4 to 20 mA DC)

Gauge

0 = None
1 = 0 to 0.2 MPa
2 = 0 to 0.4 MPa

Notes:

1. This option is just the normal operating temperature of the product and is not related to explosion protection temperature. See certificates for explosion protection temperature.

Dimensions: mm (Inches ")

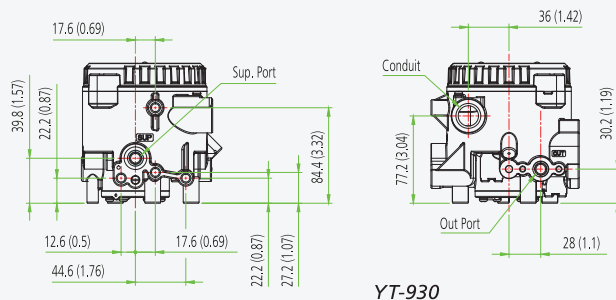

YT-930

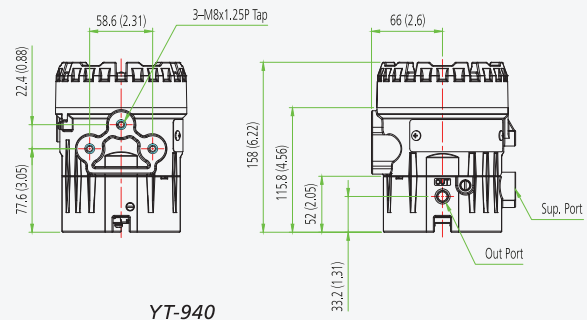

YT-940

Air Filter Regulators YT-200 / YT-205 / YT-220 / YT-225

Design features

- **Stable output and repeatability.** Provides constant control under variable flow rates and supply pressures.
- **Relief flow capability.** Discharges pressure if outer pressure is higher than set pressure.
- **Light weight and compact size.** Reduces installation costs.
- **Five micron filter.** Protects pneumatic instruments from dirty air.
- **Manual or auto draining option**



YT-200 / YT-205 Flow (LPM)

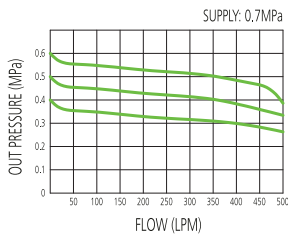

YT-220 / YT-225 Flow (LPM)

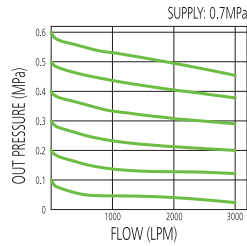

Product Code

YT-200 - A - N - 0 - 1 - 0

Model

YT-200 = Aluminium 1/4"
 YT-205 = Stainless Steel 1/4"
 YT-220 = Aluminium 1/2"
 YT-225 = Stainless Steel 1/2"

Adjustable Range

A = 0 to 0.42 MPa
 B = 0 to 0.84 MPa

Connection Type

P = Rc (N/A for YT-205/225)
 N = NPT

Gauge

0 = None
 1 = 0 to 0.4 MPa
 2 = 0 to 1.0 MPa

Operating Temp.

1 = -20 to +70 °C (-4 to +158 °F) (N/A for EAC)
 2 = -20 to +120 °C (-4 to +248 °F) (N/A for EAC)
 3 = -40 to +70 °C (-40 to +158 °F)
 4 = -50 to +70 °C (-58 to +158 °F) (only EAC)

Option

0 = Manual drain
 1 = Auto drain¹

Item Type	YT-200	YT-220	YT-205	YT-225
Max. Supply Pressure	1.7 MPa = 17 bar = 246.5 psi			
Max. Output Pressure	0.42 MPa (A Type), 0.84 MPa (B Type) 60.9 psi (A Type), 121.8 psi (B Type)			
Air Connection	Rc 1/4, 1/4 NPT	Rc 1/2, 1/2 NPT	1/4 NPT	1/2 NPT
Gauge Connection	Rc 1/4, 1/4 NPT	Rc 1/4, 1/4 NPT	1/4 NPT	1/4 NPT
Operating Temp.	-20 to +70 °C (-4 to +158 °F) (Standard type)			
Min. Filtering Size	5 micron			
Material	Aluminium Diecasting		Stainless Steel 316	
Weight (Manual drain)	0.62 kg (1.4 lb)	0.88 kg (2 lb)	1.5 kg (3.3 lb)	2.2 kg (4.8 lb)

Notes:

1. Only "1" of Operating Temp. is available

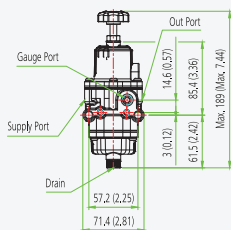

YT-200/205 Manual drain

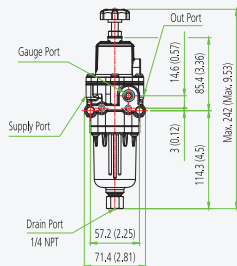

YT-200/205 Auto drain

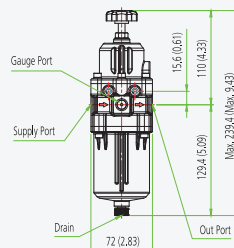

YT-220/225 Manual drain

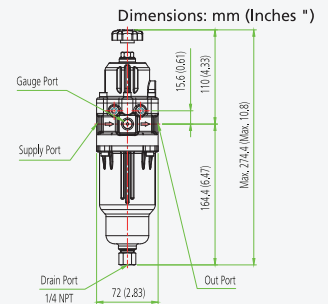

YT-220/225 Auto drain

Volume Boosters YT-300 / YT-305 / YT-320 / YT-325 / YT-310 / YT-315

Design features

- **Large flow capacity.** Specifically designed to be used in conjunction with valve positioners.
- **Optimal sensitivity.** Reacts to sudden change in supply pressure.
- **Fixed deadband.** Provides accurate and stable final positioning of the valve.
- **Internal bypass control.** Improves system stability.



YT-300

YT-325

YT-315



Item Type		YT-300 YT-305	YT-320 YT-325	YT-310 YT-315
Max. Supply Pressure		1 MPa = 10 bar = 145 psi		
Max. Signal / Output Pressure		0.7 MPa = 7 bar = 102 psi		
Signal/Output Pressure Ratio		1:1		
Flow Capacity (Cv)	Exhaust	1.32	2.08	5.24
	Output	1.19	2.72	4.91
Supply/Output Connection		Rc 1/4, 1/4 NPT	Rc 1/2, 1/2 NPT	3/4 NPT
Signal Connection		Rc 1/4, 1/4 NPT		1/4 NPT
Linearity		±1% F.S.		
Operating Temp.		-20 to +70 °C (-4 to +158 °F) (Standard type)		
Material	YT-300, YT-320, YT-310	Aluminium Diecasting		
	YT-305, YT-325, YT-315	Stainless Steel 316		
Weight	YT-300 YT-320 YT-310	0.5 kg (1.1 lb)	0.76 kg (1.7 lb)	2.3 kg (5.1 lb)
	YT-305 YT-325 YT-315	1.3 kg (2.9 lb)	1.9 kg (4.2 lb)	5 kg (11 lb)

Product Code

YT-300 - N - 1

Model

YT-300 = Aluminium 1/4"
 YT-305 = Stainless Steel 1/4"
 YT-320 = Aluminium 1/2"
 YT-325 = Stainless Steel 1/2"
 YT-310 = Aluminium 3/4"
 YT-315 = Stainless Steel 3/4"

Connection Type

(YT-305/325/310/315 are only available in NPT connection)
 P = Rc
 N = NPT

Operating Temp.

1 = -20 to +70 °C (-4 to +158 °F) (N/A for EAC)
 2 = -20 to +120 °C (-4 to +248 °F) (N/A for EAC)
 3 = -40 to +70 °C (-40 to +158 °F)
 4 = -60 to +70 °C (-76 to +158 °F) (only EAC)

Dimensions: mm (Inches ")

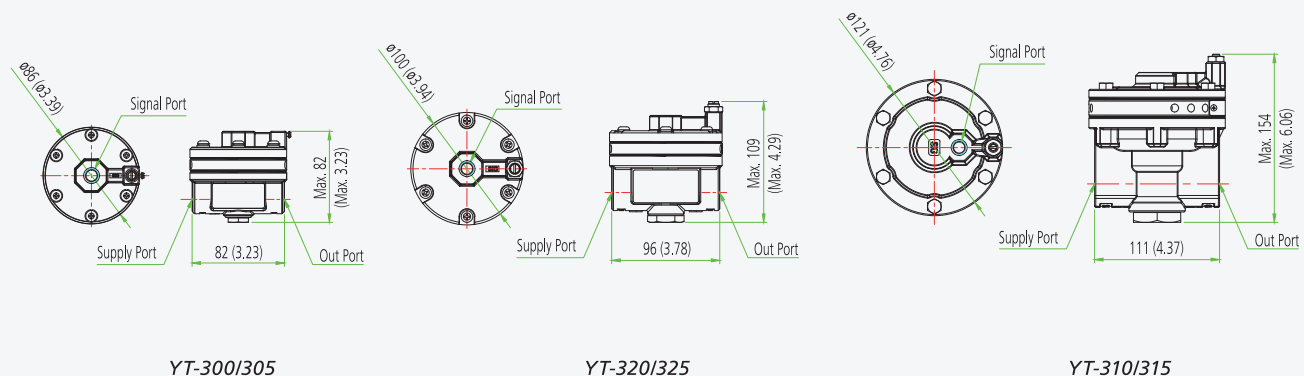

Lock-up Valves YT-400 / YT-405 / YT-430 / YT-435

Design features

- **Compact size.** No bracket is required.
- **Optimal sensitivity.** Detects small variation of the pressure - below 0.01 MPa.

Symbol

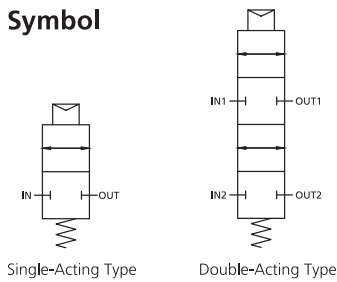

Single-Acting Type

Double-Acting Type



YT-400S

YT-405D

YT-430S

YT-435D



Item Type	YT-400	YT-405	YT-430	YT-435
Signal Pressure	0.14 to 0.7 MPa = 1.4 to 7 bar = 20 to 102 psi			
Max. Supply Pressure	Max. 1 MPa = 10 bar = 145 psi			
Signal Pressure Setting Range	Max. 0.7 MPa = 7 bar = 102 psi			
Hysteresis	Below 0.01 MPa = 0.1 bar = 1.45 psi			
Operating Temp.	-20 to +70 °C (-4 to +158 °F) (Standard type)			
Flow Capacity (Cv)	0.9		1.8	
Air Connection	Rc 1/4, 1/4 NPT	1/4 NPT	3/8 NPT	
Signal Connection	Rc 1/4, 1/4 NPT	1/4 NPT	1/4 NPT	
Material	Aluminium Diecasting	Stainless Steel 316	Aluminium Diecasting	Stainless Steel 316
Weight	Single	0.47 kg (1.1 lb)	1.3 kg (3.3 lb)	3.3 kg (7.3 lb)
	Double	0.66 kg (1.5 lb)	1.5 kg (3.3 lb)	2.7 kg (6 lb)

Product Code

YT-400 - S - P - 1

Model

YT-400 = Aluminium 1/4"
 YT-405 = Stainless Steel 1/4"
 YT-430 = Aluminium 3/8"
 YT-435 = Stainless Steel 3/8"

Acting Type

S = Single
 D = Double

Connection Type (YT-405/430/435 are only available in NPT connection)

P = Rc
 N = NPT

Operating Temp.

1 = -20 to +70 °C (-4 to +158 °F) (N/A for EAC)
 2 = -20 to +120 °C (-4 to +248 °F) (N/A for EAC)
 3 = -40 to +70 °C (-40 to +158 °F)
 4 = -50 to +70 °C (-58 to +158 °F) (only EAC)

Dimensions: mm (Inches ")

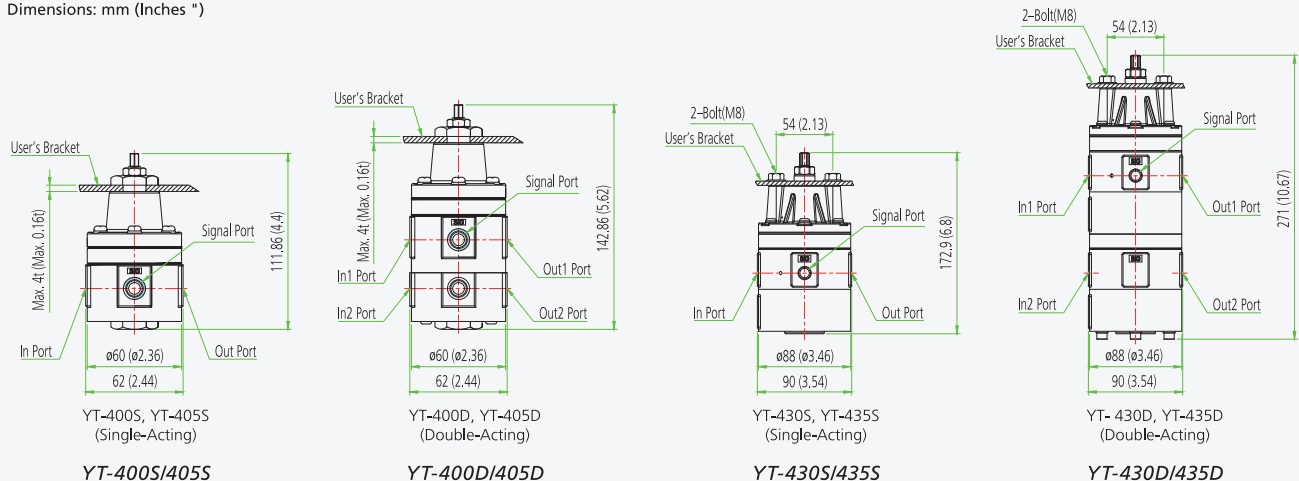

Snap Acting Relays YT-520 / YT-525 / YT-530 / YT-535

Design features

- **Rugged and reliable design.** Suitable for all environments.
- **Designed for valve actuation.** Changes the direction of the supply air to a 'fail-safe' circuit, or fail-freeze in its last known position, on sudden loss of supply air pressure.



YT-520S

YT-525D

YT-530D

YT-535S



Symbol

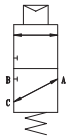

Single-Acting Type

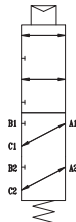

Double-Acting Type

Item Type	YT-520	YT-525	YT-530	YT-535
Hysteresis	= Below 0.01 MPa=0.1 bar=1.45 psi			
Signal Pressure	0.14 to 0.7 MPa=1.4 to 7 bar=20 to 102 psi			
Max. Supply Pressure	1 MPa=10 bar=145 psi			
Operating Temp.	-20 to +70 °C (-4 to +158 °F) (Standard type)			
Signal Connection	1/4 NPT			
A, B, C Connection	1/4 NPT		3/8 NPT	
Flow Capacity (Cv)	0.9		1.8	
Material	Aluminium Diecasting	Stainless Steel 316	Aluminium Diecasting	Stainless Steel 316
Weight	Single	0.71 kg (1.6 lb)	1.5 kg (3.3 lb)	3.3 kg (7.3 lb)
	Double	1.3 kg (2.9 lb)	3.1 kg (6.9 lb)	5.8kg (12.8 lb)

Product Code

YT-520 - S - 2 - 1

Model

YT-520 = Aluminium 1/4"
 YT-525 = Stainless Steel 1/4"
 YT-530 = Aluminium 3/8"
 YT-535 = Stainless Steel 3/8"

Acting Type

S = Single
 D = Double

Connection Type

2 = NPT

Operating Temp.

1 = -20 to +70 °C (-4 to +158 °F) (N/A for EAC)
 2 = -20 to +120 °C (-4 to +248 °F) (N/A for EAC)
 3 = -40 to +70 °C (-40 to +158 °F)
 4 = -50 to +70 °C (-58 to +158 °F) (only EAC)

Dimensions: mm (Inches ")

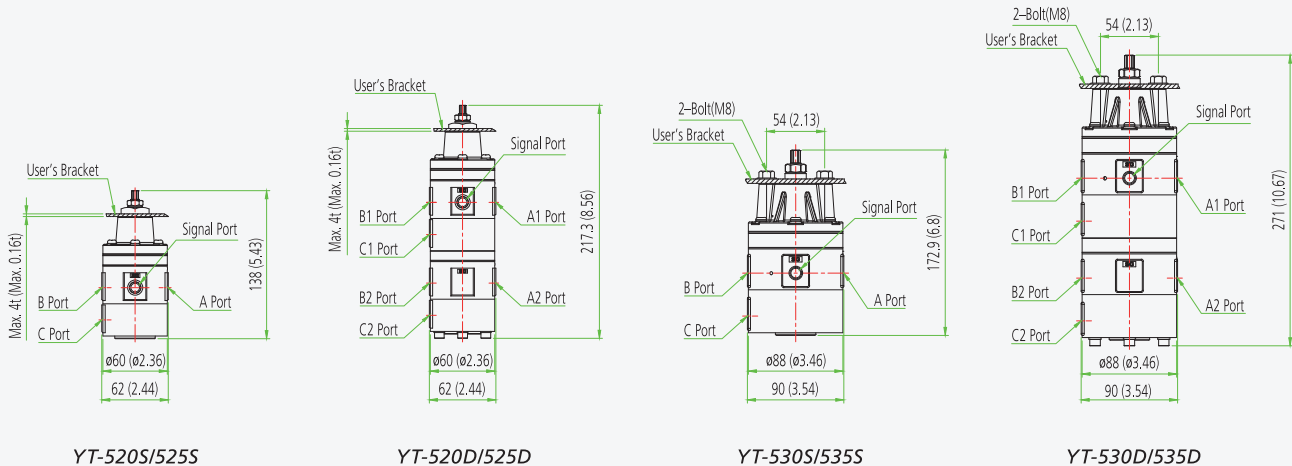

Solenoid Valve YT-720

Design features

- **Balance spool type.** No require of backing spring.
- **AC and DC Power options.** Interchangeable AC and DC coils.
- **Manual override options.** For maintenance or emergency operation.
- **Rotational connection.** Coil assembly can be rotated.

Symbol

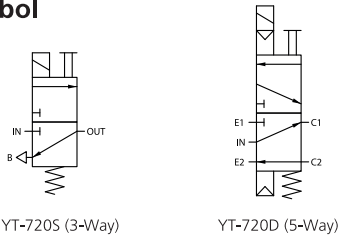

YT-720S (3-Way)

YT-720D (5-Way)



Item Type	YT-720S	YT-720D
Max. Supply Pressure	0 to 0.4 MPa 0 to 0.7 MPa	0.1 to 1 MPa
Flow Capacity (Cv)	Output	0.75
	Exhaust	
Rating Current	AC 220 V	60 mA (11 W)
	AC 110 V	130 mA (12 W)
	DC 24 V	580 mA (14 W)
Frequency	50 to 60 Hz	
Explosion Protection Type	KCs Ex d IIC T6	
Connection Type	Rc 1/4, 1/4 NPT	
Conduit	G 1/2	
Coil Insulation Grade	Class F	
Operating Temp.	Operating	-20 to +70 °C (-4 to +158 °F)
	Explosion	-20 to +50 °C (-4 to +122 °F)
Weight	0.86 kg (1.9 lb)	1.3 kg (2.8 lb)

Product Code

YT-720 - S - P - 1 - 1

Model

YT-720

Valve Type

S = 3-Way
D = 5-Way

Connection Type

P = Rc
N = NPT

Power Source

1 = AC 110 V
2 = AC 220 V
3 = DC 24 V

Pressure

1 = 0 to 0.4 MPa (3-Way)
2 = 0 to 0.7 MPa (3-Way)
3 = 0.1 to 1.0 MPa (5-Way)

Dimensions: mm (Inches ")

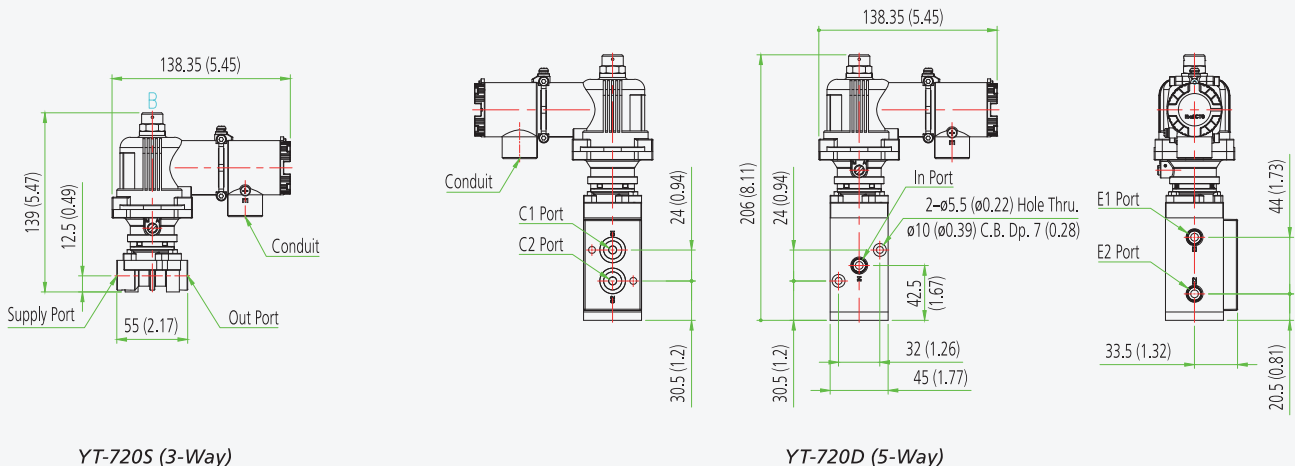

Position Transmitter SPTM-5V

Design features

- **Convenient wiring: two wire type.**
- **High accuracy and reliability.** Stable output and repeatability.
- **Simple change for RA v.s. DA action setting.**
- **Smart setting.** Easy setting of zero and span by pressing the buttons (two or five points setup).



SPTM-5V



Product Code

SPTM-5V - L - N - 1 - 0

Item Type	SPTM-5VL	SPTM-5VR
Input Type	2 Wire	
Input Stroke	10 to 150 mm	55 to 100 °
Output Signal	4 to 20 mA DC	
Load Resistance	$R_L \leq \frac{V_s[V] - 9[V]}{I [mA]}$	
Supply Voltage	9 to 28 VDC	
Conduit	G 1/2	
Operating Temp.	-40 to +85 °C (-40 to +185 °F)	
Linearity	±1% F.S.	
Hysteresis	±0.2% F.S.	
Sensitivity	±0.2% F.S.	
Ingress Protection	IP67	
Material	Aluminium Diecasting	
Weight	0.6 kg (1.3 lb)	

Model
SPTM-5V

Motion Type
L = Linear
R = Rotary

Explosion Protection
N = Non-explosion
Z = NEPSI
E = EAC

Lever Type
Linear
1 = 10 to 40 mm
2 = 20 to 70 mm
3 = 50 to 100 mm
4 = 100 to 150 mm
Rotary
1 = Standard Lever
2 = NAMUR

Option
0 = None
1 = With LCD

Dimensions: mm (Inches ")

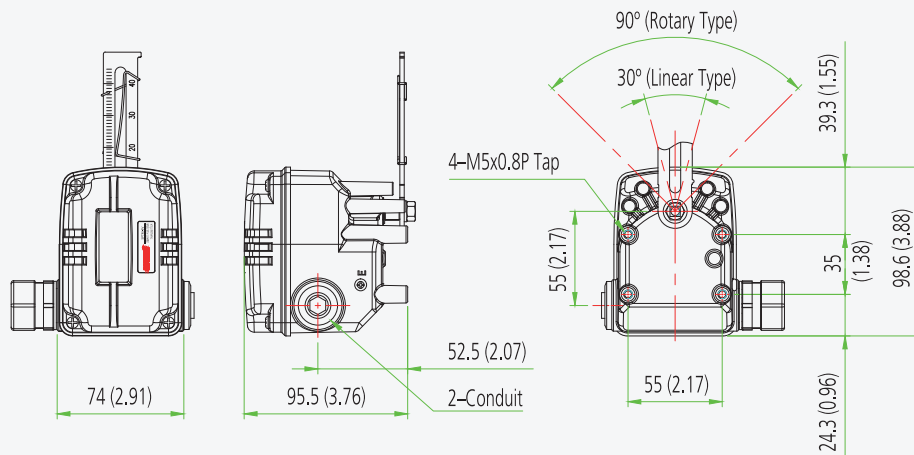

Position Transmitters SPTM-6V / SPTM-65V

Design features

- **Loop powered two wire type.**
- **High accuracy and reliability.** Stable output and repeatability.
- **Reverse or direct acting.** Easy to configure options.
- **Smart setting.** Easy setting of zero and span by pressing the buttons (two or five points setup).



SPTM-6V



SPTM-65V



Item Type	SPTM-6V	SPTM-65V
Connection Type	2 Wire	
Input Stroke	Linear	10 to 150 mm
	Rotary	55 to 100 °
Output Signal	4 to 20 mA DC	
Load Resistance	$R_{L \leq} \frac{V_s[v] - 9[v]}{I [mA]}$	
Supply Voltage	9 to 28 VDC	
Conduit	G 1/2	
Operating Temp.	Operating	-40 to +85 °C (-40 to +185 °F)
	Explosion	KCs, NEPSI: -40 to 60 °C, EAC: -60 to 60 °C
Linearity	±1% F.S.	
Hysteresis	±0.2% F.S.	
Sensitivity	±0.2% F.S.	
Explosion Protection Type	Ex d IIC T6	
Ingress Protection	IP67	
Material	Aluminium Diecasting	Stainless Steel 316
Weight	1.3 kg (2.9 lb)	2.8 kg (6.17 lb)

Product Code

SPTM-6V - L - C - 1

Model

SPTM-6V = Flameproof Aluminium
SPTM-65V = Flameproof Stainless Steel

Motion Type

L = Linear
R = Rotary

Explosion Protection

E = 1Exd IIC T6 Gb (EAC)
C = Ex d IIC T6 (KCs)
Z = Ex d IIC T6 Gb (NEPSI)

Lever Type

Linear
1 = 10 to 40 mm
2 = 20 to 70 mm
3 = 50 to 100 mm
4 = 100 to 150 mm

Rotary
1 = Standard Lever
2 = NAMUR

Dimensions: mm (Inches ")

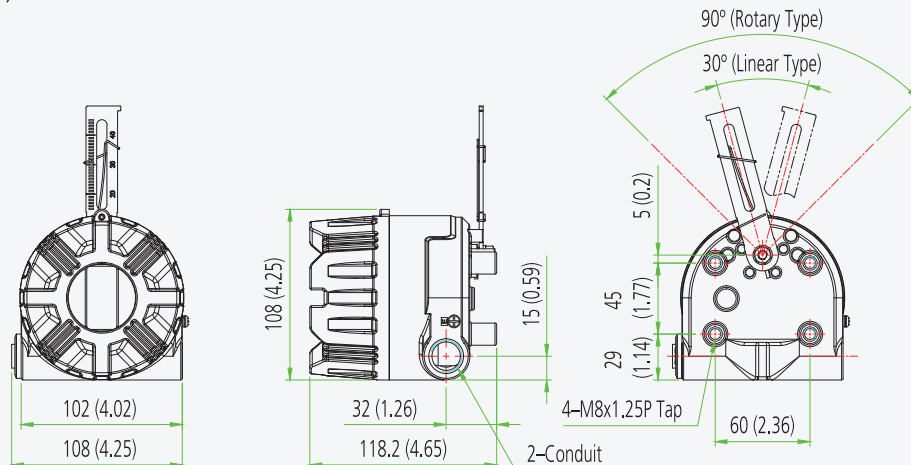

Limit Switch Box YT-850

Design features

- **Visual position indicator.** 360° viewing angle.
- **Multiple output signals.** Eight contacts of terminal ports.
- **Universal compatibility.** Suitable for any rotary motion actuator <IS05211>.
- **Easy configuration.** Simple adjustment of cam position.
- **Dual conduit entries.** Separate connections for power and signal cables.



YT-850



Item Type	YT-850M	YT-850P
Switch Type	Mechanical Switch (2xSPDT) SS5GL (Omron)	Inductive Proximity Sensor PSN17-5DNU (Autonics, NPN type)
Switch Rating	AC 250 V 3 A 125 V 5 A	-
	DC 250 V 0.2 A, 125 V 0.4 A, 30 V 4 A, 14 V 5 A, 8 V 5 A	12 - 24 VDC
Ingress Protection	IP67	
Operating Temp.	-25 to +70 °C (-13 to +158 °F)	
Conduit Entry	1/2 NPT, G1/2, M20x1.5P	
Terminal	8 Points	
Mounting Bracket	NAMUR VDI / VDE 3845, ISO 5211	
Material	Aluminium Diecasting	
Weight	880 g (1.94 lb)	

Product Code

YT-850 - M - 1 - 0

Model

YT-850 = Weatherproof Aluminium

Switching Type

M = Mechanical Switch (2xSPDT)
P = Inductive Proximity Type

Conduit

1 = 1/2 NPT
3 = G 1/4
4 = M20x1.5P

Bracket Type

0 = None
1 = ST-1 (30 x 80, H20)
2 = ST-2 (30 x 80, H30)
3 = ST-3 (30 x 130, H30)
4 = ST-4 (30 x 130, H50)

Dimensions: mm (Inches ")

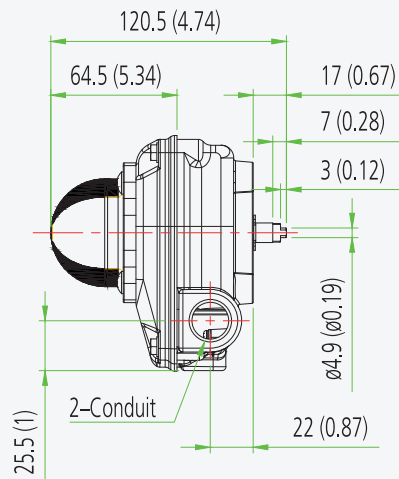
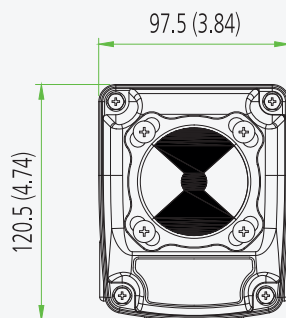

Limit Switch Boxes YT-870 / YT-875

Design features

- **Visual position indicator.** 360° viewing angle.
- **Multiple output signals.** Eight contacts of terminal ports.
- **Universal compatibility.** Suitable for any rotary motion actuator <ISO5211>.
- **Easy configuration.** Simple adjustment of cam position.
- **Dual conduit entries.** Separate connections for power and signal cables.

Item Type		YT-870M YT-875M	YT-870P YT-875P	YT-870D YT-875D
Switch Type		Mechanical Switch (2 x SPDT)	Inductive Proximity Sensor	
		SS5GL (Omron)	PS17-5DNU (Autonics, NPN type)	NJ2-V3-N (P&F, NC type)
Switch Rating		250 V 5 A 125 V 5 A	-	-
		250 V 0.2 A, 125 V 0.4 A, 30 V 4 A, 14 V 5 A, 8 V 5 A	12 - 24 V	8.2 V
				125 V or 250 V 10A
Ingress Protection		Type 4, 4X, IP 67		
Explosion Protection Type		ATEX, IECEx Ex db IIC T6, Ex tb IIIC T85°C CSA Ex db IIC T6 Class I, Zone 1, AEx db IIC T6 Class II, Division 1, Groups E, F and G, Ex tb IIIC T85°C Zone21, AEx tb IIIC T85°C KCs Ex d IIC T6 CCC Ex d IIC T6 Gb Ex tD A21 IP67 T85°C		
Operating Temp.		-20 to +60 °C (-4 to +140 °F)		
Conduit Entry		YT-870: 3/4 NPT, G 3/4, M20x1.5P, 1/2 NPT YT-875: 3/4 NPT		
Terminal		YT-870D, 875D = 12 Points		
Mounting Bracket		NAMUR VDI / VDE 3845, ISO 5211		
Material and Weight		YT-870 Aluminium Diecasting: 1.5 kg (3.3 lb) YT-875 Stainless Steel 316: 3.5 kg (7.7 lb)		



YT-870



YT-875



Product Code

YT-870 - M - 1 - 0 - 0 -

Model

YT-870 = Flameproof Aluminium
YT-875 = Flameproof Stainless Steel

Switching Type

M = Mechanical Type (2 x SPDT)
P = Inductive Proximity Type¹
D = Mechanical Type (2 x DPDT)

Conduit

1 = 3/4 NPT
2 = G3/4 (YT-870 only)
3 = M20x1.5P (YT-870 only)
4 = 1/2 NPT (YT-870 only)

Bracket Type

0 = None
1 = ST-1 (30x80,H20)
2 = ST-2 (30x80,H30)
3 = ST-3 (30x130,H30)
4 = ST-4 (30x130,H50)

Option

0 = None
1 = SPTM²

Explosion Protection

Blank = N/A for CCC
Z = CCC

Notes:

- Standard type is PN17-5DNU (Autonics, NPN type). But PSN17-5DPU (Autonics, PNP) and NJ2-V3-N (P&F, NC type) are also available.
- Only M of Switching type is available.

Dimensions: mm (Inches ")

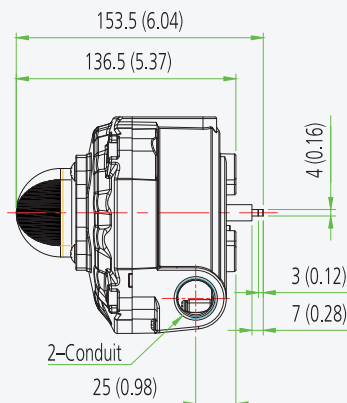
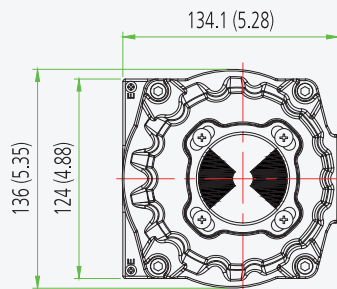

Examples for Installation (Linear Type)

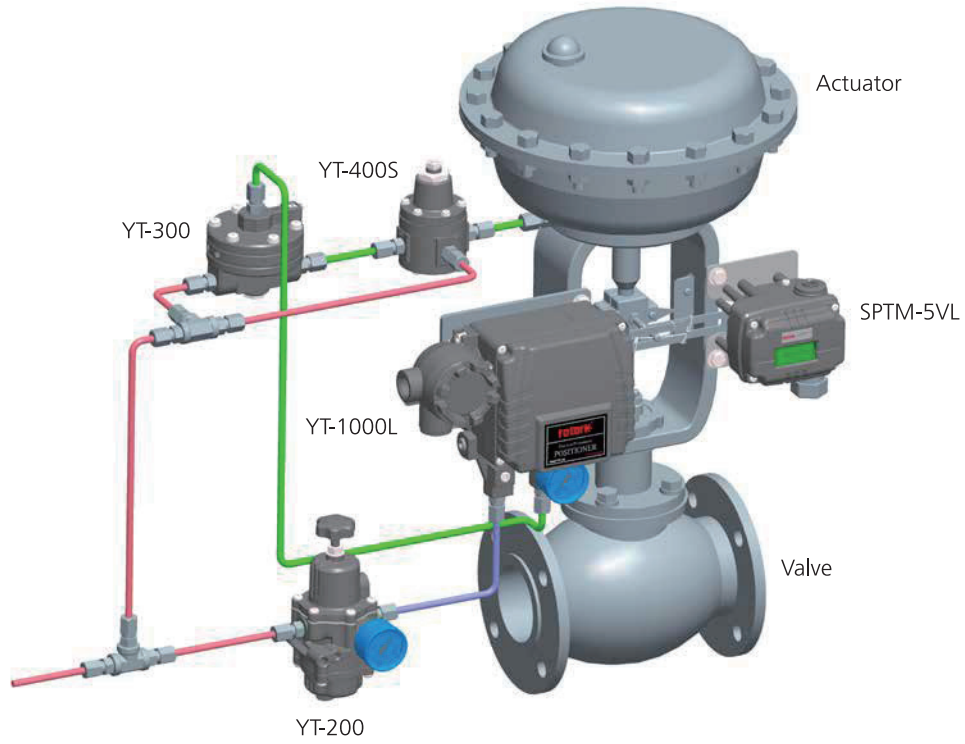

YF1000L (Single type) Application Example

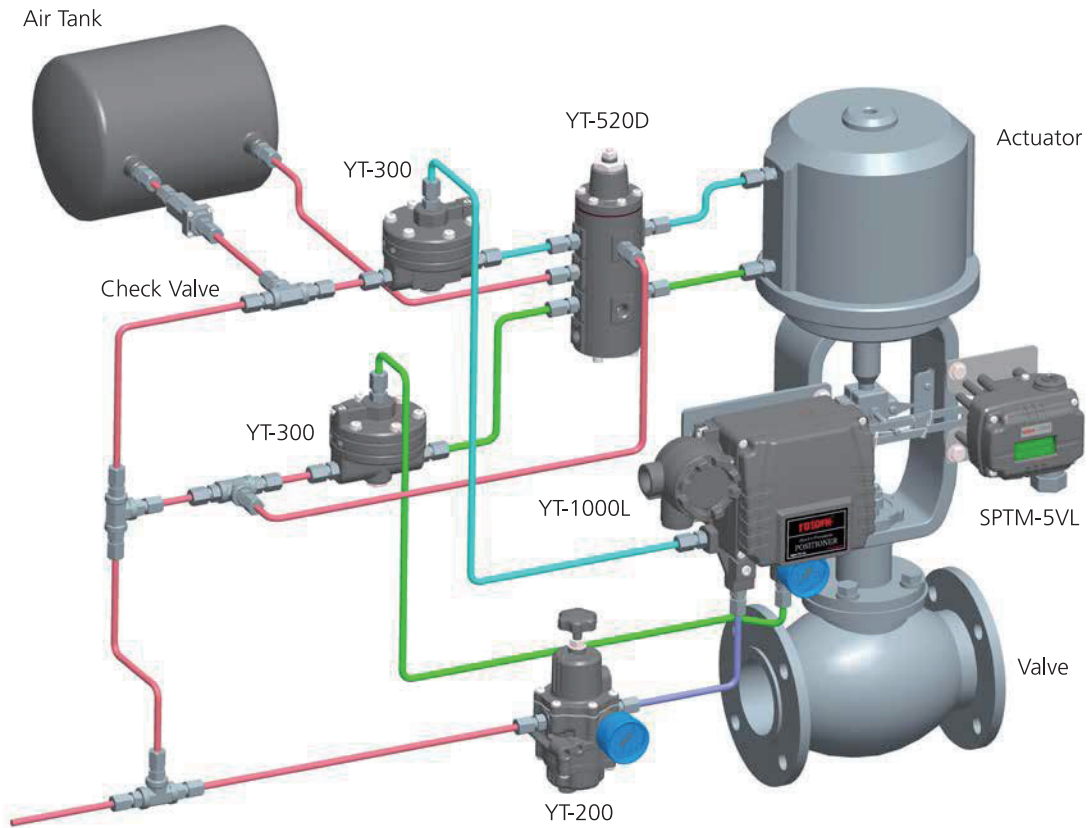

YF1000L (Double type) Application Example

Examples for Installation (Rotary Type)

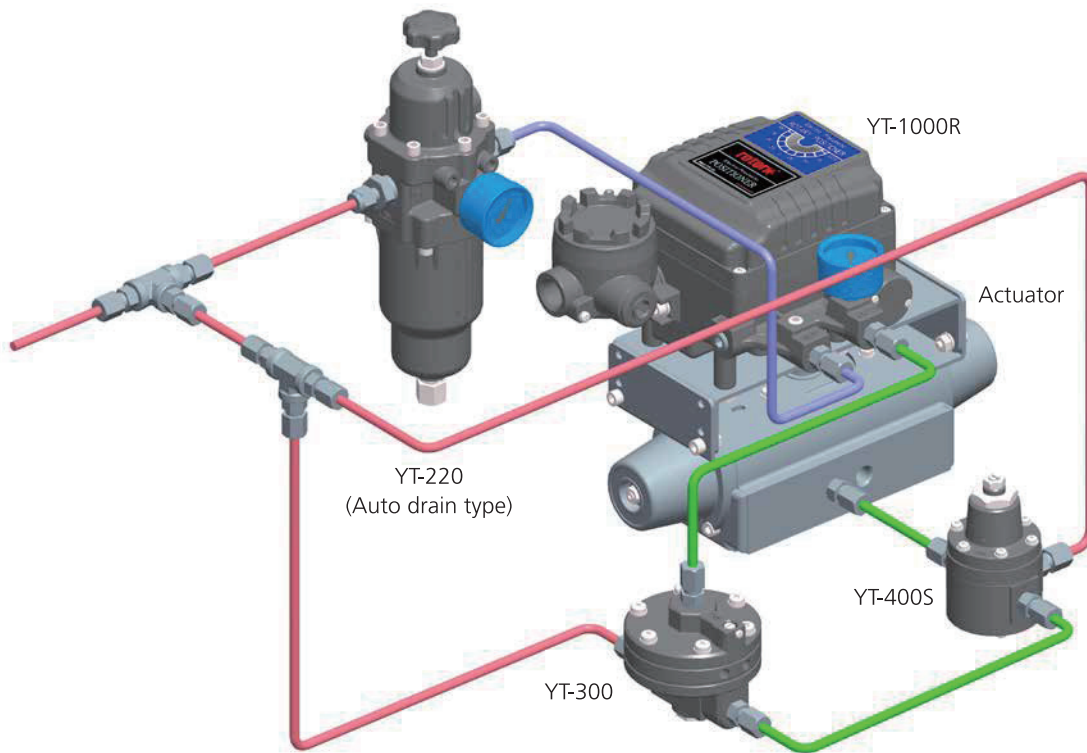

YT-1000R (Single type) Application Example

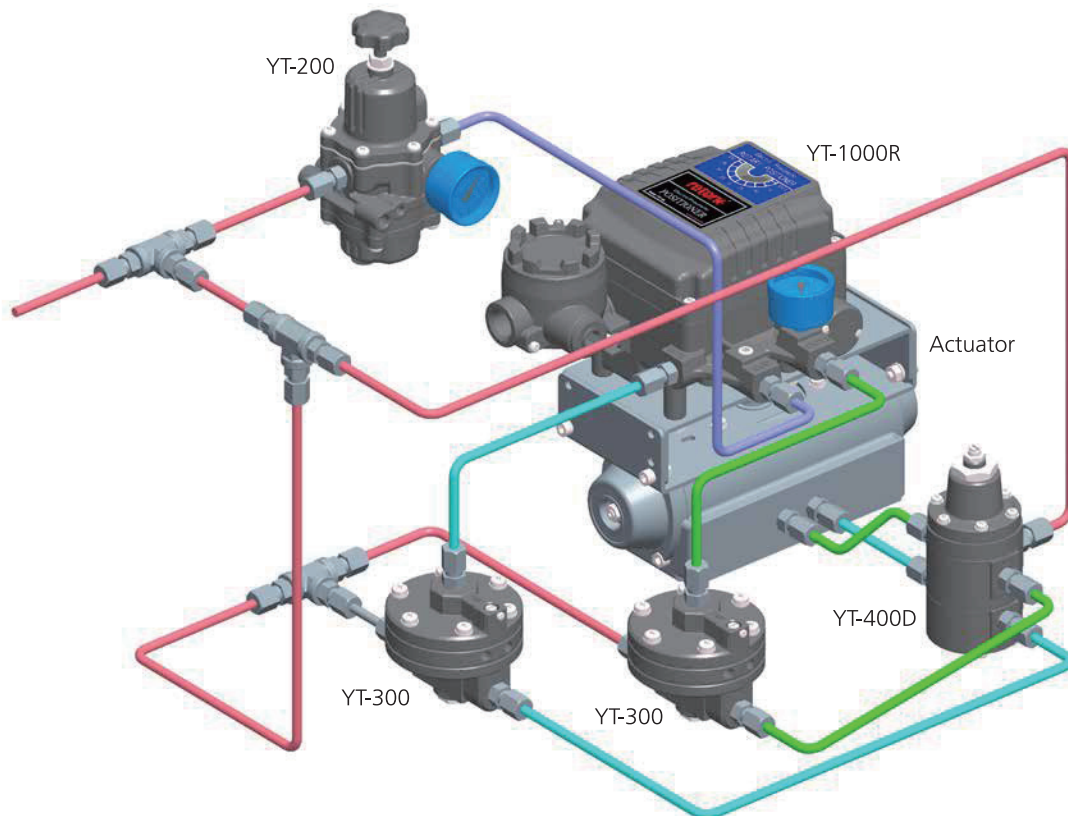

YT-1000R (Double type) Application Example

Brackets and Levers

YT-1000R Bracket Series

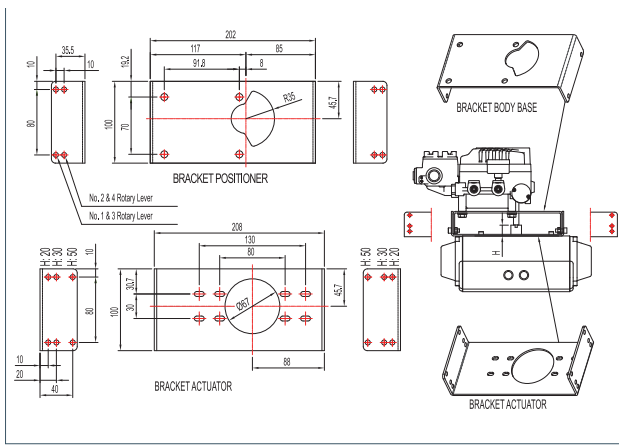

YT-1200R Bracket Series

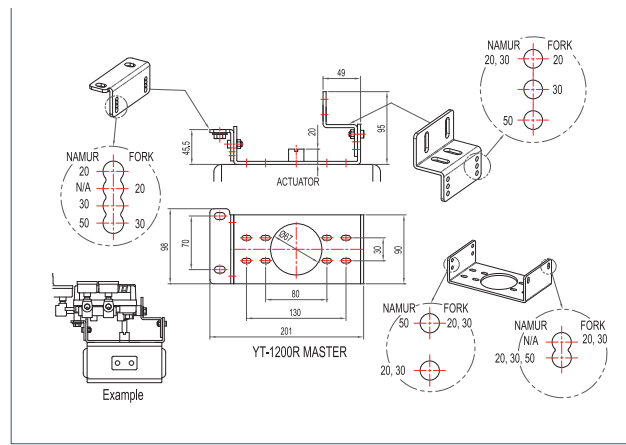

YT-2500R & 2550R & 2600R & 3303R & 3400R & 3450R Bracket Series

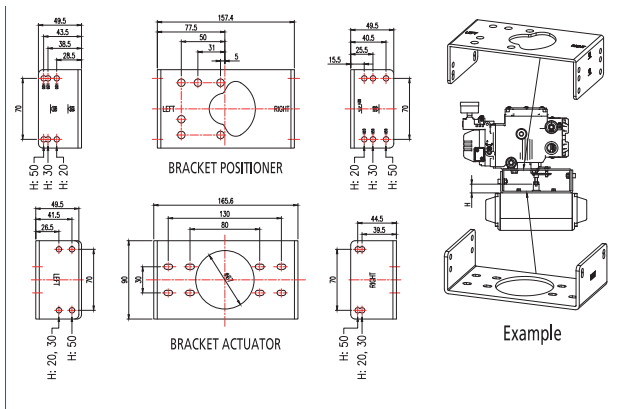

YT-3300R & 3350R & 3700R & 3750R Bracket Series

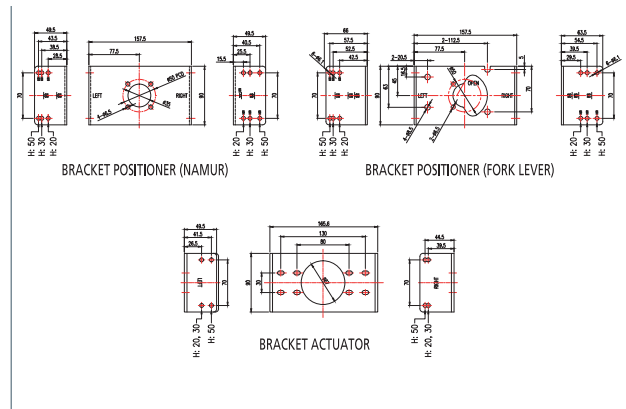

Linear Type Namur Bracket Series

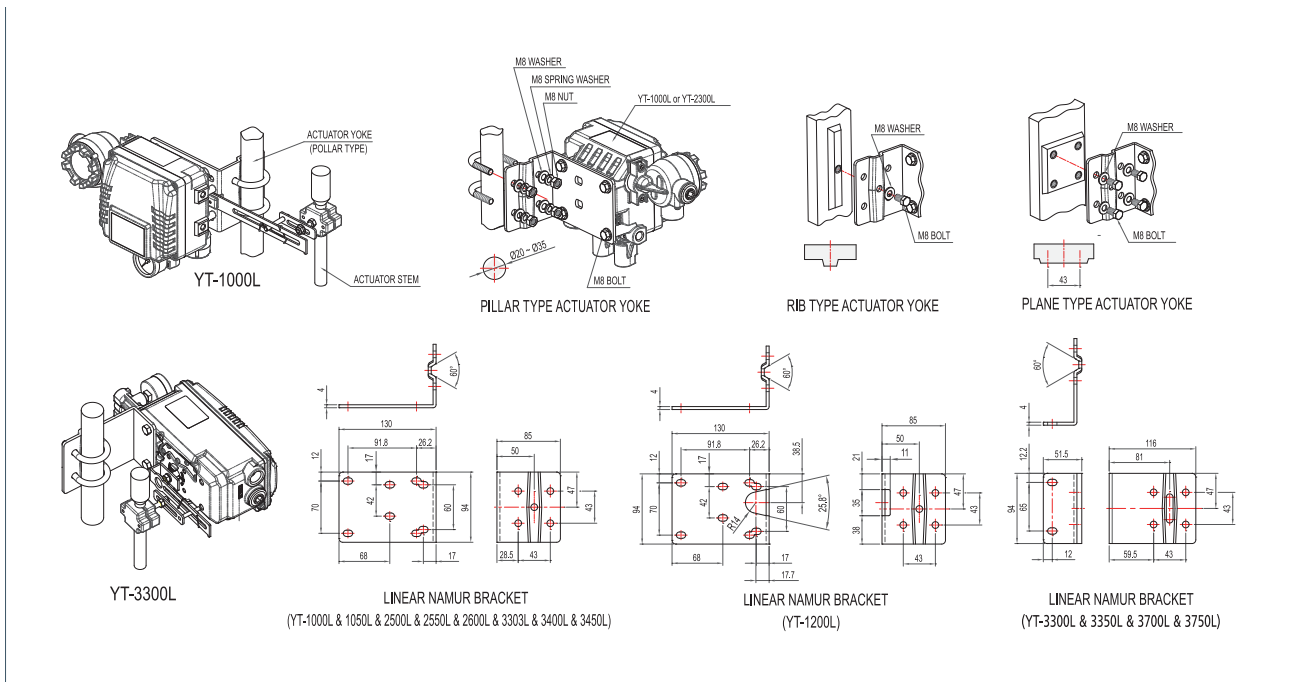

Brackets and Levers

YT-850 & 870 & 875 Bracket Series

Bracket Type	H1	H2	UNIT: mm	
			L1	L2
ST-1	20	30.5	80	100
ST-2	30	40.5		
ST-3	30	40.5		
ST-4	50	60.5	130	150

Lever Series

Lever Type	Stroke	UNIT: mm	
		L1	L2
1	10 - 40	121.2	68.2
2	30 - 70	195	120
3	60 - 100	277	122
4	100 - 150	400	

Type 1, 2, 3

Type 4

YT-1000 & 1200 Linear Type

SPTM-5V Rotary Standard Lever Type

SPTM-6V & SPTM-65V Rotary Standard Lever Type

Lever Type	Stroke	UNIT: mm	
		L1	L2
1	10 - 40	93	67
2	20 - 70	153.5	106.5
3	50 - 100	214	117
4	100 - 150	307.3	

Rotary Fork Lever Type

Model	UNIT: mm	
	L1	L2
E/P & P/P Positioner	7	11
Smart Positioner & SPTM-6V & SPTM-65V	4	8
SPTM-5V	4	9
YT-850 & 870 & 875	3	7

Rotary Namur Lever Type

Lever Type	Stroke	UNIT: mm		
		L1	L2	L3
0 (Standard)	10 - 40	45	55	40.9
1 (Standard)	20 - 100	91	115	
2 (Standard)	90 - 50	85	165	
3 (Adapter)	16 - 30	27	43	
4 (Adapter)	16 - 60	64	80	
5 (Adapter)	16 - 100	96	113	
6 (Adapter)	90 - 150	80	167	167

Type 0, 1, 2

Type 3, 4, 5, 6

YT-3300 & 3350 & 3700 & 3750 Linear Type

Appendix A: Equipment Certification Requirements for Hazardous Locations

ATEX & IECEx

Typical ATEX & IECEx Marking [*ATEX only]

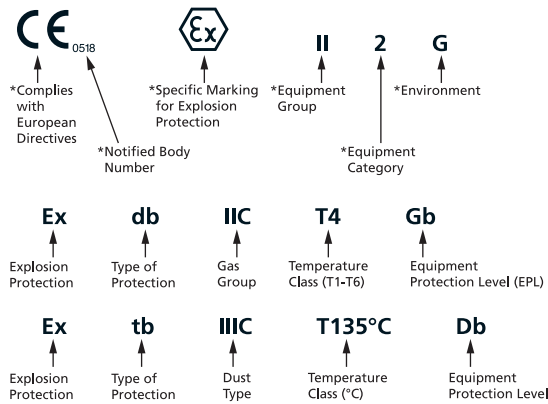

Protection Concepts

Type of Protection	Symbol	Typical IEC EPL	Typical Zone(s)	IEC Standard	Basic Concept of Protection
Electrical Equipment for Gases, Vapours and Mists (G)					
General Requirements	-	-	-	IEC 60079-0	-
Optical Radiation	Op pr Op sh Op is	Gb Ga Ga	1, 2 0, 1, 2 0, 1, 2	IEC 60079-28	Protection against ignitions from optical radiation
Increased Safety	eb ec	Gb Gc	1, 2 2	IEC 60079-7	No arcs, sparks or hot surfaces. Enclosure IP54 or better
Type 'n' (non-sparking)	nA	Gc	2	IEC 60079-15	-
Flameproof	da db dc	Ga Gb Gc	0, 1, 2 1, 2 2	IEC 60079-1	Contain the explosion, quench the flame
Type 'n' (enclosed break)	nC	Gc	2	IEC 60079-15	-
Quartz / Sand Filled	q	Gb	1, 2	IEC 60079-5	Quench the flame
Intrinsic Safety	ia ib ic	Ga Gb Gc	0, 1, 2 1, 2 2	IEC 60079-11	Limit the energy of sparks and surface temperatures
Type 'n' (sealing & hermetic sealing)	nC	Gc	2	IEC 60079-15	-
Type 'n' (restricted breathing)	nR	Gc	2	IEC 60079-15	Keep the flammable gas out
Encapsulation	ma mb mc	Ga Gb Gc	0, 1, 2 1, 2 2	IEC 60079-18	-
Electrical Equipment for Combustible Dusts (D)					
General Requirements	-	-	-	IEC 60079-0	-
Optical Radiation	Op pr Op sh Op is	Db Da Da	21, 22 20, 21, 22 20, 21, 22	IEC 60079-28	Protection against ignitions from optical radiation
Enclosure	ta tb tc	Da Db Dc	20, 21, 22 21, 22 22	IEC 60079-31	Standard protection for dusts, rugged tight enclosure
Intrinsic Safety	ia ib ic	Da Db Dc	20, 21, 22 21, 22 22	IEC 60079-11	Limit the energy of sparks and surface temperatures
Encapsulation	ma mb mc	Da Db Dc	20, 21, 22 21, 22 22	IEC 60079-18	Protection by encapsulation of incandescence parts
Electrical Equipment for Combustible Dusts (D)					
General Requirements	-	-	-	EN 13463-1	-
Flow Restricted Enclosure	fr	-	-	IEC 80079-36	Low potential energy
Flameproof Enclosure	d	-	-	EN 13463-3	Relies on tight seals, closely matched joints and tough enclosures to restrict the breathing of the enclosure
Constructional Safety	c	-	0, 1, 2 20, 21, 22	EN 13463-5	Ignition hazards eliminated by good engineering methods
	h	Ga, Gb, Gc Da, Db, Dc	0, 1, 2 20, 21, 22	IEC 80079-37	-
Control of Ignition Source	b	-	-	EN 13463-6	Control equipment fitted to detect malfunctions
	h	Ga, Gb, Gc Da, Db, Dc	0, 1, 2 20, 21, 22	IEC 80079-37	-

cCS Aus

Typical North American Marking (CSA)

Class I, Division 1, Groups A,B,C,D T4



Class II, Division 1, Groups E,F,G



Class I, Zone 0, AEx ia IIC T4



Protection Concepts

Type of Protection	Code	Country	Class	Division / Zone	Standard	Basic Concept of Protection
Electrical Equipment for Flammable Gas, Vapors and Mists - Class I						
General Requirements	AEx Ex	US CA	Class I Class I	Division 1 & 2 Zone 1 & 2	FM 3600 - ISA 60079-0 CSA 60079-0	-
Increased Safety	AEx e Ex e	US CA	Class I Class I	Zone 1 Zone 1	ISA 60079-7 CSA C22.2 No. 60079-7	-
Non-Incendive	(NI) (NI)	US CA	Class I Class I	Division 2 Division 2	ISA 12.12.01 / FM 3611 C22.2 No. 213	No arcs, sparks or hot surfaces
Non-Sparking	AEx nA Ex nA	US CA	Class I Class I	Zone 2 Zone 2	ISA 60079-15 CSA C22.2 No. 60079-15	-
Explosion Proof	(XP) (XP)	US CA	Class I Class I	Division 1 Division 1	UL 1203 / FM 3615 C22.2 No. 30	-
Flameproof	AEx d Ex d	US CA	Class I Class I	Zone 1 Zone 1	ISA 60079-1 UL 1203 / FM 3615 CSA 60079-1	Contain the explosion and extinguish the flame
Enclosed Break	AEx nC Ex nC	US CA	Class I Class I	Zone 2 Zone 2	ISA 60079-15 CSA C22.2 No. 60079-15	-
Intrinsic Safety	(IS) (IS)	US CA	Class I Class I	Division 1 Division 1	UL 913 / FM 3610 C22.2 No. 157	-
	AEx ia Ex ia	US CA	Class I Class I	Zone 0 Zone 0	ISA 60079-11 / FM 3610 ISA 60079-11 / FM 3610	Limit energy of sparks and surface temperature
	AEx ib Ex ib	US CA	Class I Class I	Zone 1 Zone 1	ISA 60079-11 / FM 3610 CSA C22.2 No. 60079-11	-
	AEx ic Ex ic	US CA	Class I Class I	Zone 2 Zone 2	ISA 60079-11 / FM 3610 CSA C22.2 No. 60079-11	-
Limited Energy	AEx nL Ex nL	US CA	Class I Class I	Zone 2 Zone 2	ISA 60079-15 CSA C22.2 No. 60079-15	-
Restricted Breathing	AEx nR Ex nR	US CA	Class I Class I	Zone 2 Zone 2	ISA 60079-15 CSA C22.2 No. 60079-15	Keep flammable gas out
Encapsulated	AEx ma AEx m Ex m AEx mb	US CA US	Class I Class I Class I	Zone 0 Zone 1 Zone 1	ISA 60079-18 ISA 60079-18 CSA C22.2 No. 60079-18 ISA 60079-18	Keep flammable gas out
Electrical Equipment for Flammable Gas, Vapors and Mists - Class I						
General Requirements	Ex	US CA US CA US	Class II Class II Class III Class III	Division 1 & 2 Division 1 & 2 Division 1 & 2 Zone 20, 21, 22	FM 3600 CSA C22.2 No.0 FM 3600 CSA C22.2 No.0 ISA 60079-0	-
Dust Ignition Proof	-	US CA	Class II Class II	Division 1 Division 1	UL 1203 / FM 3616 CSA C22.2 No. 25	-
Dust Protected	-	US CA	Class II Class II	Division 2 Division 2	ISA 12.12.01 / FM 3611 CSA C22.2 No. 25	-
Protection by Enclosure	AEx ta AEx tb AEx tc	US US US	Class II Class II Class II	Zone 20 Zone 21 Zone 22	ISA 60079-31 ISA 60079-31 ISA 60079-31	Keep combustible dust out
	Ex ta Ex tb Ex tc	US CA CA	Class II Class II Class II	Zone 20 Zone 21 Zone 22	CSA C22.2 No. 60079-31 CSA C22.2 No. 60079-31 CSA C22.2 No. 60079-31	-
	AEx maD AEx mbD	US US	- -	Zone 20 Zone 21	ISA 60079-18 ISA 60079-18	-
	(IS) (IS)	US CA	Class II Class II	Division 1 Division 1	UL 913 / FM 3610 CSA C22.2 No. 157	Limit energy of sparks and surface temperature
Intrinsic Safety	AEx iaD AEx ibD	US US	- -	Zone 20 Zone 21	ISA 60079-11 ISA 60079-11	-
	(IS) (IS)	US CA	Class III Class III	Division 1 Division 1	UL 913 / FM 3610 CSA C22.2 No. 157	-

Appendix A: Equipment Certification Requirements for Hazardous Locations

ATEX & IECEx Certificate Number

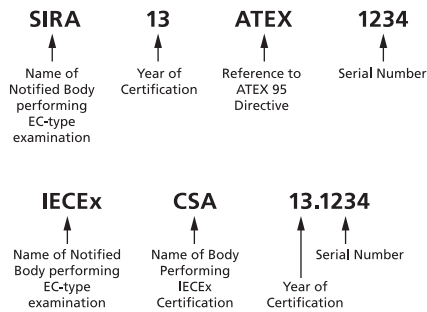

Suffixes: U – component certification
X – special conditions for safe use apply

Apparatus Groups [ATEX and IECEx]

Group	Environment	Location	Typical Substance
I		Coal Mining	Methane (Fire damp)
IIA	Gases, Vapours	Surface and other locations	Acetic acid, Acetone, Ammonia, Butane, Cyclohexane, Gasoline (petrol), Kerosene, Methane (natural gas) (non-mining), Methanol (methyl alcohol), Propane, Propan-2-ol (iso-propyl alcohol), Toluene, Xylene
IIB			Di-ethyl ether, Ethylene, Methyl ethyl ketone (MEK), Propan-1-ol (n-propyl alcohol), Ethanol (ethyl alcohol)
IIC			Acetylene, Hydrogen, Carbon disulphide
IIIA	Combustible Dusts	Surface and other locations	Combustible flyings
IIIB			Non-conductive
IIIC			Conductive

Apparatus Groups (US / CAN)

Substance	Hazard Class	NEC 500	NEC 505
Acetylene	Class I Flammable Gases	Group A	IIC
Hydrogen		Group B	IIC
Ethylene		Group C	IIB
Propane		Group D	IIA
Methane (mining)		Group D	-
Combustible Metal Dusts	Class II Combustible Dusts	Group E	-
Combustible Carbonaceous Dusts		Group F	-
Combustible Dusts not in Group E or F (Flour, Grain, Wood, Plastics, Chemicals)		Group G	-
Combustible Fibers and Flyings		-	-
	Class III Fibers and Flyings	-	-

Classification of Divisions and Zones

Type of Area	NEC and CEC*	ATEX and IEC	Definitions
Continuous hazard	Division 1	Zone 0 / Zone 20 Cat 1	A place in which an explosive atmosphere is continuously present
Intermittent hazard	Division 1	Zone 1 / Zone 21 Cat 2	A place in which an explosive atmosphere is likely to occur in normal operation
Hazard under abnormal conditions	Division 2	Zone 2 / Zone 22 Cat 3	A place in which an explosive atmosphere is not likely to occur in normal operation, but may occur for short periods

* On occasion the ATEX and IEC Zones may be used in the corresponding NEC and CEC system

Temperature Classification

Classification of maximum surface temperatures for Group II Electronic Equipment (T Class).

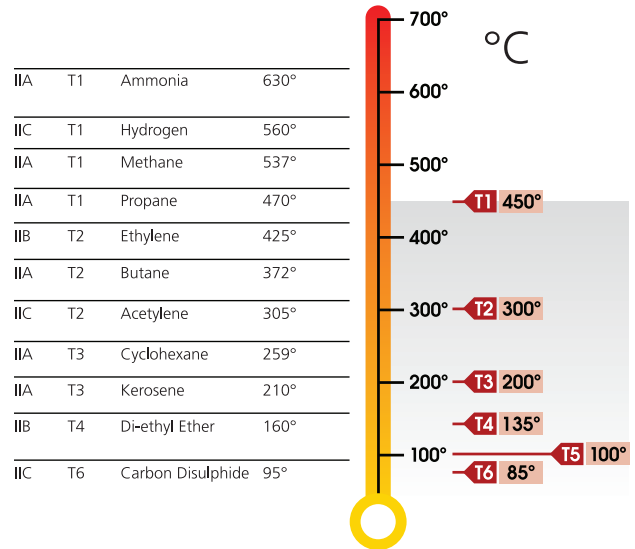

Dusts Typical Ignition Temperatures (°C)

Dusts	Cloud	Layer
Aluminium	590 °C	>450 °C
Coal dust (lignite)	380 °C	225 °C
Flour	490 °C	340 °C
Grain dust	510 °C	300 °C
Methyl cellulose	420 °C	320 °C
Phenolic resin	530 °C	>450 °C
Polythene	420 °C	(melts) °C
PVC	700 °C	>450 °C
Soot	810 °C	570 °C
Starch	460 °C	435 °C
Sugar	490 °C	460 °C

Ingress Protection Codes

First Number (protect from solid bodies)		Second Number (protect from water)	
0	No protection	0	No protection
1	Objects > 50mm	1	Vertical drip
2	Objects > 12.5mm	2	Angled drip
3	Objects > 2.5mm	3	Spraying
4	Objects > 1.0mm	4	Splashing
5	Dust-protected	5	Jetting
6	Dust-tight	6	Powerful jetting
		7	Temporary immersion
		8	Continuous immersion

Enclosure Type Ratings (NEMA / CSA / UL)

Type	Area	Brief Definition
1	Indoor	General purpose
2	Indoor	Protection against angled dripping water
3, 3R, 3S	Indoor / Outdoor	Protection against rain, snow
4, 4X	Indoor / Outdoor	Protection against rain, snow, hose directed water
5	Indoor	Protection against angled dripping water, dust, fibers, flyings
6	Indoor / Outdoor	Protection against temporary submersion
6P	Indoor / Outdoor	Protection against prolonged submersion
12, 12K	Indoor	Protection against circulating dust, fibers, flyings
13	Indoor	Protection against circulating dust, fibers, flyings, seepage

Appendix B: Certifications



Product Type	Model Number	Cert. Type	Rating	
Electro-Pneumatic Positioner	YT-1000 / 1050	ATEX	II 2G Ex db mb IIB T5 Gb	
		IECEX	Ex db mb IIB T5 Gb	
		EAC	1Ex d mb IIB T5 Gb X IP66	
		INMETRO	Ex db mb IIB T5 Gb	
		FM	XP-SA/1/CD/T5 Ta=60°C; DIP/II,III/1/EFG/T5 Ta=60°C; Type 4X	
		CSA	(Class I, Zone 1) Ex dm IIB T5	
	YT-1000	CCC	Ex d mb IIB T5 Gb:CCC, Ex d mb IIC T6 Gb:CCC, Ex ia IIC T6 Ga:CCC	
		TIIS	Ex dmb IIB T5	
		TS	Ex db mb IIB T5 Gb X Ex dmb IIB T5/T4	
		KCs	Ex d IIC T5 IP66 Ex ia IIB T6 Gb	
		YT-1050	KCs	Ex dmb IIB T5
		Smart Positioner	YT-3300 / 3350 / 3303 / 3301 / 3400 / 3450 / 3700 / 3750	SIL
YT-3300 / 3350	NEPSI		Ex ia IIC T5/T6 Gb	
	ATEX		Ex ia IIC T5/T6 Gb, EX ia IIIC T100°C/T85°C Db IP66	
	IECEX		Ex ia IIC T5/T6 Gb, EX ia IIIC T100°C/T85°C Db IP66	
	EAC		1Ex ia IIC T6...T5 Gb X / Ex ia IIIC T85°C...T100°C Db X 0Ex ia IIC T6...T5 Ga X / Ex ia IIIC T85°C...T100°C Da X IP66	
	YT-3300 / 3350 / 3303 / 3301		INMETRO	Ex ia IIC T6/T5 Gb Ex ia IIIC T85°C/T100°C Db IP66
			CCOE	Ex ia IIC T5/ T6 Gb
YT-3300 / 3350 / 3303 / 3301	FM		Class I, Div 1, Groups ABCD; Class I, Zone 0 AEx ia IIC; Class II/III, Div 1, Groups EFG; Class I, II, III, Div 2, Groups ABCDEFG; NEMA Type 4 IP66	
YT-3300 / 3350 / 3303 / 3301	CSA		Class I, Division 1/2, Groups ABC and/or D T5/T6 Class II, Division 1/2, Groups EF and/or G T100°C/T85°C; Class III Ex ia IIC T5/T6 Ga; Ex tb IIIC T100°C/T85°C Db	
	CCC		Ex ia IIC T5/T6 Gb, Ex iaD 21 T100/T85	
	KCs		Ex ia IIC T5/T6, EX iaD IIIC T100°C/T85°C	
	YT-3300 / 3350 / 3303 / 3301		KCs	Ex ia IIC T5/T6, EX iaD IIIC T100°C/T85°C
			KCs	Ex ia IIC T5/T6, EX iaD IIIC T100°C/T85°C
			KCs	Ex ia IIC T5/T6, EX iaD IIIC T100°C/T85°C
YT-3400 / 3450	ATEX		Ex db IIC T5/T6, Ex tb IIIC T85°C/T100°C	
	IECEX		Ex db IIC T5/T6, Ex tb IIIC T85°C/T100°C	
	FM		XP/II/ABCD/T6 Ta= -40°C to +70°C, T5 Ta= -40°C to +80°C I/1/AEx db/IIC/T6 Ta= -40°C to +70°C, T5 Ta= -40°C to +80°C DIP/II, III/1/EFG/T6 Ta= -40°C to +70°C, T5 Ta= -40°C to +80°C 21/AEx tb/IIIC/T85°C Ta= -40°C to +70°C, T100°C Ta= -40°C to +80°C; IP66	
	CSA		Ex db IIC T5 or T6; Class I, Zone 1, AEx db IIC T5 or T6; Class II, Division 1, Groups E, F and G; Ex tb IIC T85°C/T100°C; AEx tb IIIC T85°C/T100°C	
	YT-2500		CCC	Ex d IIC T5/T6 Gb, Ex tD A21 IP66 T85°C/T100°C
			EAC	1Ex d IIC T6...T5 Gb X Ex tb IIIC T85°C...T100°C Db X IP66
NEPSI		EX d IIC T5/T6 Gb, Ex tD A21 IP66 T85°C/T100°C		
YT-3400		INMETRO	Ex db IIC T5/T6 Gb IP66 Ex tb IIIC T85 °C/T100 °C Db IP66	
		ECAS	Ex db IIC T5/T6 Gb, Ex tb IIIC T100°C/T85°C Db	
YT-3400		KCs	Ex d IIC T5/T6 IP66	
YT-3450	KCs	Ex d IIC T5/T6, Ex tb IIIC T85°C/T100°C		
YT-2500	EAC	1Ex ia IIC T6...T5 Gb X Ex ia IIIC T85°C...T100°C Db X IP66		
	NEPSI	Ex ia IIC T5/T6 Gb Ex iaD 21 T100/T85		

Appendix B: Certifications

Product Type	Model Number	Cert. Type	Rating	
Smart Positioner	YT-2500 / 2550 / 2501	ATEX	Ex ia IIC T5/T6 Gb, Ex ia IIIC T85°C/T100°C IP6X	
		IECEX	Ex ia IIC T5/T6 Gb, Ex ia IIIC T85°C/T100°C IP6X	
		CCC	Ex ia IIC T5/T6 Gb, Ex iaD 21 T100/T85	
		KCs	Ex ia IIC T5/T6, EX iaD IIIC T100°C/T85°C	
	YT-2600	ATEX	Ex db IIC T5/T6, Ex tb IIIC T85°C/T100°C	
		IECEX	Ex db IIC T5/T6, Ex tb IIIC T85°C/T100°C	
		KCs	Ex d IIC T5/T6 IP66	
		CCC	Ex d IIC T5/T6 Gb, Ex tD A21 IP66 T85°C /T100°C	
		EAC	1Ex d IIC T6...T5 Gb X Ex tb IIIC T85°C...T100°C Db X IP66	
		YT-3700 / 3750	ATEX	Ex ia IIC T5/T6 Gb, Ex ia IIIC T100°C/T85°C Db IP 6x
	IECEX		Ex ia IIC T5/T6 Gb, Ex ia IIIC T100°C/T85°C Db IP 6x	
	CCC		Ex ia IIC T5/T6 Gb, Ex iaD 21 T100/T85	
	KCs		Ex ia IIC T6/T5, Ex ia IIIC T85°C/T100°C	
	FM		Class I, Div 1, Groups ABCD, Class I, Zone 0 AEx ia IIC, Class II/III, Div 1, Groups EFG, Class I, II, III, Div 2, Groups ABCDEFG, Zone 21 AEx tb IIIC T100°C...T85°C, NEMA Type 4X IP66 or IP54, AMBIENT TEMP:-40°C to 60°C(T5) / -40°C to 40°C(T6)	
	CSA		Ex ia IIC T6/T5 Gb ; Ex ia IIIC T85°C/T100°C Db, Class I, Division 1 and Division 2, Groups A, B, C, D T6/T5, Class II, Division 1 and Division 2, Groups E, F, G, T85°C/T100°C, Class III.	
	INMETRO		Ex ia IIC T6/T5 Gb, Ex ia IIC T85°C/T100°C Db IP66	
	EAC		1Ex ia IIC T6...T5 Gb X / Ex ia IIIC T85°C...T100°C Db X 0Ex ia IIC T6...T5 Ga X / Ex ia IIIC T85°C...T100°C Da X IP66	
	ECAS		Ex db IIC T5/T6 Gb, Ex tb IIIC T100°C/T85°C Db	
	YT-930		ATEX	Ex ia IIC T5/T6 Gb, Ex ia IIIC T100°C/T85°C Db
		IECEX	Ex ia IIC T5/T6 Gb, Ex ia IIIC T100°C/T85°C Db	
	IP Converter	YT-940	FM	Class I Division 1, Groups A, B, C, D; T6 Ta= -40°C to +75°C, T5 Ta= -40°C to +85°C; Type4X, IP66 Class II, III Division1, Groups E, F, G; T6 Ta=-40°C to+75°C, T5 Ta=-40°C to+85°C; Type4X, IP66 Class I, Zone 1, AEx d IIC T6 Ta= -40°C to + 75°C, T5 Ta= -40°C to +85°C, Type 4X, IP66 Zone 21 AEx tb IIIC T85°C Ta= -40°C to +75°C, T100°C Ta= -40°C to +85°C, Type 4X, IP66
			CSA	Ex db IIC T5 or T6 Ex tb IIIC T85°C/T100°C, IP66
			KCs	Ex d IIC T5/T6
			KCs	Ex d IIC T6
Solenoid Valve	YT-720	EAC	1Ex d IIC T6 Gb IP66	
		CCC	Ex d IIC T6 Gb	
		KCs	Ex ia IIC T5	
Position Transmitter	SPTM-5V	EAC	1Ex ia IIC T5 Gb IP67	
		NEPSI	Ex ia IIC T5 Gb	
	SPTM-6V / 65V	KCs	Ex d IIC T6 IP67	
		EAC	1Ex d IIC T6 Gb IP67	
		NEPSI	Ex d IIC T6 Gb	
		ATEX	Ex db IIC T6, Ex tb IIIC T85°C	
		IECEX	Ex db IIC T6, Ex tb IIIC T85°C	
		Limit Switch	YT-870 / 875	CSA
CCC	Ex d IIC T6 Gb Ex tD A21 IP67 T85°C			
KCs	Ex d IIC T6			
Volume Booster	YT-300 / 305 / 320 / 325 / 310 / 315	SIL	SIL2/SIL3	

rotork®



www.rotork.com

A full listing of our worldwide sales and service network is available on our website.

Rotork plc
Brassmill Lane, Bath, UK
tel +44 (0)1225 733200
email mail@rotork.com

Rotork
81, Hwanggeum-ro 89 beon-gil, Yangchon-eup,
Gimpo-si, Gyeonggi-do, South Korea, 10048
web www.ytc.co.kr
tel +82 31 986 8545
fax +82 70 4170 4927
email ytcsales@rotork.com

Rotork is a corporate member of the Institute of Asset Management



PUB126-001-00
Issue 01/20

As part of a process of on-going product development, Rotork reserves the right to amend and change specifications without prior notice. Published data may be subject to change. For the very latest version release, visit our website at www.rotork.com

The name Rotork is a registered trademark. Rotork recognises all registered trademarks. Published and produced in the UK by Rotork. POWTG0120